

GREENHOUSE GAS REDUCTION PATHWAYS
IN THE UNFCCC PROCESS UP TO 2025

– TECHNICAL REPORT –

Authors: P. Criqui^{*}, A. Kitous^{*}, M. Berk⁺, M. den Elzen⁺, B. Eickhout⁺, P. Lucas⁺, D. van Vuuren⁺, N. Kouvaritakis[°] and D. Vanregemorter[§]

with contributions from: B. de Vries⁺, H. Eerens⁺, R. Oostenrijk⁺ and L. Paroussos[°]

^{*} CNRS/LEPII-EPE (France)

⁺ RIVM-MNP (Netherlands)

[°] ICCS-NTUA (Greece)

[§] CES-KUL (Belgium)

October 2003

Greenhouse gas Reduction Pathways: Executive summary

Chapter 1: Targets and reduction pathways

(Note: this text is based on the executive summary of the Greenhouse gas Reduction Pathways Policymakers Summary)

The long-term objective of the European Union climate policy is to prevent global mean temperature rising by more than 2°C over pre-industrial levels. Without policy induced constraints this target will be missed by a substantial margin. According to model-based estimates and projections, if no further action to control emissions is taken concentrations of greenhouse gas in the atmosphere may increase from 425 parts per million volume (ppmv) CO₂-equivalent today to 935 ppmv CO₂-equivalent in 2100. This could cause global temperature to rise by more than 3°C by 2100.

To explore the implications of the EU climate target, two constrained global emission profiles have been developed. They correspond to stabilising the total greenhouse gas concentration at levels of 550 and 650 ppmv in CO₂ equivalent, for the set of six greenhouse gases covered by the Kyoto Protocol. These profiles are hereafter referred to as S550e and S650e.

The range of the temperature rise associated with these two emission profiles depends on the uncertainty about the 'climate sensitivity' parameter, which is defined as the global average temperature rise resulting from doubling CO₂ concentrations. The Intergovernmental Panel on Climate Change (IPCC) estimates the range of the climate sensitivity to be from 1.5 to 4.5°C, with a median value of 2.5°C.

Using this uncertainty range, the S550e profile will result in a global mean temperature rise of less than 2°C for a low to median value of the climate sensitivity. The S650e profile only stays below this value if the climate sensitivity is at the low end of the range. This means that this profile is less likely to meet the EU target. If the climate sensitivity is high, the EU target will not be met in either profile.

The profiles clearly differ in the timing and level of the emission reductions needed. Global emissions must peak as soon as 2015-2020 under the S550e profile, and around 2030 in the S650e profile. Delaying emission reductions would imply very steep global reductions later or overshooting the targeted concentration levels, leading to a bigger rise in temperature.

The abatement effort required in the constrained profiles may be measured by the percentage change in anthropogenic greenhouse gas emissions from their 1990 level, and from the baseline projection (that is, the levels they would have reached without specific abatement actions). For greenhouse gas emissions from energy use and industrial processes this implies:

- In 2025 global emission levels can still rise about 20% above 1990 levels in the S550e profile, but this already implies reducing emissions by one third compared to the baseline projection. In the S650e profile, the reduction compared to the baseline is smaller, but still significant, at around 15%.
- In 2050 emissions have to be reduced strongly in the S550e profile, not only compared to the baseline level (65%), but also compared to 1990 levels (15%). In contrast, in S650e, greenhouse gas emissions can still be 50% above their 1990 level by 2050. However, compared to the baseline, global emissions need to be reduced by about 35%.

Chapter 2 : Architectures for the international climate regime

The greenhouse gas emission reductions required are thus substantial. In this perspective, the Kyoto Protocol is only a very first step in climate policies. At the same time, approaches based on binding quantified emission targets combined with mechanisms for a flexible

implementation, such as the 'Kyoto Mechanisms' provide an efficient incentive structure for implementing the required reductions. Proposals for other types of regimes have been made as well, such as technology standards or voluntary efficiency targets, but these probably provide a less comprehensive system of incentives and less certainty for meeting the required level of reductions.

After 2012, a deepening and broadening of the climate change commitments under the UNFCCC is required. This raises the question of how to do this in a fair and acceptable way, particularly given the need for economic development in many parts of the world. Very different responses to this question can be identified. They differ for instance with respect to the very definition of the problem, the equity principles upon which they are based, the way targets are set, and the timing for participation of the different Parties.

As far as equity principles are concerned, they usually refer to more general notions or concepts of distributive justice or fairness. Among the key principles explored or invoked in the international climate negotiation up to now, one can identify:

- *Egalitarian*, i.e. each human being has an equal right to use the atmosphere.
- *Sovereignty and acquired rights*, all countries have a right to use the atmosphere and current emissions constitute a 'status quo right'.
- *Responsibility / polluter pays*, the greater the contribution to the problem, the greater the share in the mitigation / economic burden.
- *Capability*, the greater the capacity to act or ability to pay and the greater the share in the mitigation / economic burden.

Another key aspect in the characterisation of the climate policy architectures is in the question of whether all Parties participate immediately on the basis of simultaneously defined endowments in a global emission profile, or if the number of Parties as well as the stringency of their commitments is gradually increased. The development of the international architecture may take two different paths:

- The institution of a structural regime with the adoption of a set of rules or targets that define the evolution of emission quotas for all Parties over a long time period. This type of regime may be called a '*full participation*' regime.
- An incremental approach to the extension of the climate regime, with a gradual expansion of the Annex I group of countries adopting binding quantified emission limitation or reduction objectives, absolute or dynamic. This type of solution may be called an '*increasing participation*' regime and, when different categories of countries and targets are considered, a '*multi-stage*' regime.

The study of the international commitment schemes included an exploratory phase and a phase with more in-depth analyses of a limited number of solutions. In the first phase, three 'full participation' regimes – described as *Per Capita Convergence*, *Soft Landing* and *Global Preference Score* – and three 'increasing participation' regimes – described as *Brazilian proposal*, *Ability To Pay*, and *Multi-Stage* – have been examined. This preliminary exercise allowed to identify the main features of the various approaches and to select the approaches for the in-depth analysis.

Chapter 3 : Regional long-term endowments in selected approaches

Two schemes proved to be sufficiently generic and have been selected for more in-depth analysis: the Per Capita Convergence as representing a 'full participation' option, and the Multi-Stage as representing an 'increasing participation' option. For each scheme, different variants were evaluated under the two global emissions profiles derived above (S550e and S650e).

For the Per Capita Convergence scheme, two time-horizons have been considered for the final convergence (2050 and 2100), in order to describe two cases that impose different constraints on Annex I countries in the short to medium term: the Per Capita Convergence-2050 and Per Capita Convergence-2100 cases.

As far as the 'Multi-Stage' approach is concerned, three alternative cases have been developed. All of them are based on the same definition of the consecutive stages for the commitments of non-Annex I countries, i.e.: Stage 1 with no commitment, Stage 2 with carbon intensity (or dynamic) targets and Stage 3. with absolute emission targets.

The threshold used for the transition from Stage 1 to Stage 2 is also common and is based on a 'Capacity-Responsibility index', defined as the sum of per capita GDP and per capita emissions in each region. The three cases – Multi-Stage 1, Multi-Stage 2 and Multi-Stage 3 – differ however in the way the transition from Stage 2 to Stage 3 is made: in Multi-Stage 1, the second threshold is based on world average per capita emissions; in Multi-Stage 2 this threshold is again based on a CR index, while in Multi-Stage 3 the transition is based on a differentiated transition period for the stabilisation of emissions.

A first general conclusion from the analysis is that the Annex I countries' endowments are largely comparable in the different Multi-Stage variants and the Per Capita Convergence-2050 case. The endowments by 2025 for all Annex I regions are in the order of 40-60% below the baseline for the S550e profile and 15-40% for the S650e profile. In 2050, reductions are in the order of 80% (S550e) to 50% (S650e). By contrast, the Per Capita Convergence-2100 case results in substantially larger endowments for the Annex I countries than all other cases.

Regarding the endowments of non-Annex I regions, the results of the various Multi-Stage and Per Capita Convergence cases are quite sensitive to particular assumptions, such as the participation thresholds and the global emission profile. No general conclusion for this group as a whole can be drawn. For the S550e profile, the Multi-Stage 3 variant tends to result in larger endowments for the more developed non-Annex I regions, while for the least developed regions, it is the case in Multi-Stage 2. For the S650e profile, in the short-term (2025) the results of the different variants are quite similar due to the late participation of most non-Annex I regions.

Chapter 4 : Economic assessment of the emission profiles and endowment schemes

The assessment of the economic implications of the different schemes has been performed on the basis of partial equilibrium as well as full general equilibrium analyses. In the first approach, the costs of domestic abatement and of emission trading resulting from the regional allocation of emissions are analysed at the level of emitting sectors. In the second approach, the macro-economic costs implied by the necessary adjustments in the technical and economic systems are also considered. This approach thus also takes into account the changes in sector activity levels and international trade that are due to emission constraints.

In all cost calculations a least-cost implementation is assumed, based on the assumption of international emission trading. This implies that the implementation of reduction options and the global costs are largely independent from the emission endowment schemes. However, as far as the costs for the different regions are concerned, they of course crucially depend on the endowments to each Party.

Meeting the S550e or the S650e profiles will require major changes in world consumption of energy and other greenhouse gas emitting activities. It will also induce new dynamics in the use and the diffusion in new technologies, not only in the energy sector, but also in industry and agriculture. These changes contribute to the costs of mitigation action.

The global mitigation costs for meeting the S550e profile are much higher than for S650e. For the S550e profile global effort rate (i.e. the mitigation costs as a percentage of GDP) increases fast after 2020 towards the middle of the century to a maximum level of approximately 1.2% of the world GDP, after which this effort rate gradually decreases to 0,6% by 2100. For the S650e profile, the global effort rate increases more gradually to 0.2% by 2050 and stabilises in the last quarter of the century at a level of approximately 0.3%. These costs mostly reflect the degree of stringency of the emission reduction targets.

As a general rule, regions with high per capita emissions and a high income (the OECD regions, as of 1990) are confronted with average effort rates. Regions with medium to high per capita emissions, but a medium to low income (the Community of Independent States, Latin America and the Middle East, but also China) are confronted with high effort rates. Regions with low per capita emissions and a low income (in Africa and Asia) are confronted with the lowest effort rates and can even gain from emissions trading.

With respect to the magnitude of macro-economic costs, in general a correlation between the results of emission trading and welfare changes is found.

The region that benefits most in terms of welfare is South Asia (mainly India and Pakistan). Because of relatively abundant endowments, it is a net exporter of quotas in all cases. High positive welfare impacts are also present in the other Asian regions, while the outcomes for Africa are to some extent negatively influenced by the existence within the region of large oil producers and exporters.

The key conclusions emerging from the general equilibrium analysis of the different endowment schemes are as follows:

- The introduction of flexibility mechanisms, such as international emission trading, allows to limit the costs of abatement policies and makes the total global costs in principle independent of the endowment schemes.
- Regional abatement costs and macro-economic impacts show large differences among regions. Particularly, the Middle East and the Community of Independent States regions experience substantially larger costs than the other regions.
- The Multi-Stage schemes provide in both profiles better welfare prospects for the developing regions, as they imply high income transfers in 2025.

Chapter 5 : Co-benefits of climate policies, the case of air pollution

The potential co-benefits of the mitigation scenarios are considerable. Indeed the significant changes in energy consumption and in the energy system that would result from greenhouse gas abatement actions may have significant side effects, in particular as far as the emissions of regional air pollutants are concerned.

Currently, both climate change policies and air quality control are still relatively marginal issues in most low-income countries, particularly when compared to issues such as poverty eradication, or as food, water and energy supply. In order to curb the risks of fast growing emissions of both air pollutants and greenhouse gases in these countries, use could be made of the synergies between sustainable development targets and climate change.

The preliminary assessment of the potential co-benefits of the greenhouse gas reduction pathways defined in this study has been performed while adopting two different approaches:

- The first one focuses on the atmospheric emissions of SO₂ and NO_x, in a modelling framework that is based on the linking of the TIMER and of the RAINS models; changes in emissions are described in physical units, but the use of proxy indicators for air pollution effects allows to better characterize the positive consequences of greenhouse gas reduction policies; this approach is particularly relevant for those

world regions that combine a rapid growth in their economic and energy systems and an already high vulnerability to air pollution problems, as is the case for Asia.

- The second approach is developed in a general equilibrium framework and uses the 'state of the environment' module of the GEM-E3 model; the transferability of data gathered in Europe or in the US to other world regions still raises important problems and the results should thus be considered as preliminary; however, this exercise allows to produce a first assessment of environmental co-benefits assessed in terms of welfare, which can be usefully compared with the costs of greenhouse gas abatement policies.

Changes from the baseline in global sulphur and nitrogen oxides emissions in the constrained emission profiles are significant, as emissions from these gases would be significantly reduced as a side effect of climate policies. The S650e profile leads to world-wide reductions of sulphur and nitrogen oxide emissions of 50% and 35% from baseline, respectively. The S550e profile leads to even stronger reductions, i.e. 70% and 50%.

These results can also be analysed on a regional basis. This shows that co-benefits will occur in all regions. However, as emissions of both sulphur and nitrogen oxides are comparatively larger in the low-income regions, due to currently less strict air pollution control policies, the co-benefits are more important in these regions. Particularly, in the Asian regions with high baseline emissions climate policies would thus incur significant reductions.

All studies undertaken so far show the importance of the links between climate and air quality policies. They seem to be significant in terms of direct impact, but also highly relevant in terms of policy design. The economic studies of the co-benefits of GHG mitigation suggest that the avoided damages may compensate for a significant part of the costs of GHG emission reductions.

Conclusions

Meeting the EU objective of limiting global average temperature increase to 2 degrees Celsius above pre-industrial levels requires a peak in global greenhouse gas emissions within the next two decades. This means that early participation of developing countries in global emission control is needed, even under a significant strengthening of the commitments of Annex I countries under the Kyoto Protocol.

The study has shown that it is possible to design a set of consistent rules for the attribution of the long-term emission endowments of the different world regions. Because the Multi-Stage schemes include the possibility of commitments of a different nature for regions with different levels of wealth and emissions intensity, they may seem good candidates for defining a long-term international climate architecture with an acceptable distribution of endowments and costs.

The gains from participating in global emission trading and from reduced air pollution damage and/or abatement costs does substantially enhance, from a developing country perspective, the attractiveness of an early participation in a regime based on greenhouse gas reduction pathways, provided that the level and the form of their commitment is well designed so as to minimise economic risks.

This perspective may help to fully design the extended Kyoto architectures that would provide the right combination of information, incentive and constraint that is required to stimulate the development of new low-emission technologies and consumption patterns.

– TABLE OF CONTENTS –

<i>Greenhouse gas Reduction Pathways: Executive summary</i>	<i>ii</i>
<i>Introduction</i>	<i>1</i>
<i>1. Global emission constraints and baseline emission scenario assumptions</i>	<i>3</i>
1.1. Baseline scenario for the 1995 - 2100 period.....	3
1.2. Emission profiles for the stabilisation of greenhouse gas concentration at 550 and 650 ppmv	6
1.3. Impacts on temperature.....	9
1.4. Implications for emission reductions.....	10
1.5. Conclusions.....	11
<i>2. A review and selection of the approaches to international commitment schemes.....</i>	<i>13</i>
2.1. The dimensions of international commitment schemes.....	13
2.2. The selected endowment rules for the first phase of the Greenhouse gas Reduction Pathways study	15
2.3. Characterisation of the six selected approaches	16
2.4. Outcomes of the different approaches assessed in the first phase of the study	17
2.4.1. The commitment schemes and resulting endowments.....	18
2.4.2. Key conclusions.....	19
<i>3. The long-term endowment schemes: design, key parameters and resulting endowments.....</i>	<i>21</i>
3.1. Key assumptions for the Per Capita Convergence and Multi-Stage cases	21
3.1.1. Two Per Capita Convergence cases: convergence in 2050 and in 2100	21
3.1.2. Three simplified Multi-Stage schemes to emission commitments	21
3.1.3. Hypotheses for the Multi-Stage cases in the S550e constraint	23
3.1.4. Assumptions for the Multi-Stage cases under the S650e constraint	24
3.2. Regional endowments under the S550e constraint	25
3.2.1. S550e, reductions from Reference case to 2025 and 2050	25
3.2.2. Robustness of results for the S550e profile.....	27
3.3. Regional endowments under the S650e constraint	29
3.3.1. S650e, reductions from Reference case to 2025 and 2050	29

3.3.2. Robustness of results for the S650e profile.....	30
3.4. Conclusions.....	31
4. Abatement costs and impacts on the energy systems and on the economies	35
4.1. Impacts on the energy sector from the POLES model.....	35
4.1.1. World carbon price.....	35
4.1.2. The S550e profile	36
4.1.3. The S650e profile	38
4.1.4. The pattern of international emission trading.....	40
4.1.5. Synthesis on effort rates in S550e and S650e for 13 regions	43
4.1.6. Impacts on the World Energy Balances.....	44
4.2. Economic assessment of endowment schemes with the GEM-E3 model	47
4.2.1. Introduction.....	47
4.2.2. Methodology and design of model applications.....	48
4.2.3. Results.....	48
4.2.4. Model based quota endowment scheme.	55
4.2.5. Conclusions	58
4.3. Long term abatement costs and emission trading with the FAIR model	59
4.3.1. World prices and global effort.....	59
4.3.2. Regional abatement and trading under the S550e and S650 profiles	60
4.3.3. Financial flows	62
4.3.4. Effort rates	64
4.3.5. Abatement action within the long-term energy system	66
4.3.6. Conclusions	71
5. Co-benefits of mitigation actions	73
5.1. Co-benefits from the FAIR-TIMER-RAINS modeling	73
5.1.1. Co-benefits of climate policies for regional air pollution control.....	73
5.1.2. Potential co-benefits of the S550e and S650e mitigation scenarios.....	75
5.1.3. Looking into more detail to changes in Asia	81
5.1.4. Conclusions	83
5.2. Evaluation of co-benefits from GEM-E3 and ExterneE	83
5.2.1. Methodology for evaluating co-benefits in GEM-E3 World	83
5.2.2. Co-benefits in the Multi-Stage 3 scenarios	85
References.....	89

Introduction

This report describes the analyses that have been performed in the '*Greenhouse gas Reduction Pathways in the UNFCCC process*' study and it provides the background materials to the corresponding Policymakers Summary. The *Greenhouse gas Reduction Pathways study* has aimed in particular at identifying the set of options to be explored and discussed in the Post-Kyoto international negotiation process. For that purpose, five key issues have been considered and fully analysed in the following sequence:

- Chapter 1 identifies the emission pathways that should be followed in order to respect the EU's climate targets, while considering the state of the art in the scientific knowledge on the relations between greenhouse emissions and concentrations, concentrations and temperature change.
- Chapter 2 provides a synthetic review of the main types of architectures that have been up-to-now proposed either in the scientific literature or in the negotiation process, in order to design international quantitative emission targets systems.
- Chapter 3 starts from the selection of two generic and representative architectures and then describes their consequences in terms of emission endowments, for the different regions of the world.
- Chapter 4 provides an in-depth assessment of the economic consequences of these endowment schemes, while using three different economic models: the IMAGE-TIMER and POLES model for partial equilibrium analyses – respectively in the very long-term (2050-2100) and in the medium term (2025) – and the GEM-E3 model for the general equilibrium analysis in the medium term.
- Finally, Chapter 5 describes the co-benefits to be expected from greenhouse gas emission reduction policies, as analysed in terms of positive environmental impacts on a local or regional scale for the different regions of the world, but particularly for the less developed ones.

1. Global emission constraints and baseline emission scenario assumptions

In 1996 the EU Council adopted as its long-term climate policy objective the fact of *preventing global mean temperature to increase beyond 2°C over its pre-industrial level*. RIVM has used this long-term climate target to develop alternative greenhouse gas emission profiles that could be consistent with this 2°C target, taking into account the uncertainty regarding the sensitivity of the climate system (Eickhout et al., 2003). The emission profiles constructed result in a stabilisation of the concentration of greenhouse gas at a level of 550 and 650 ppmv carbon dioxide equivalents, respectively (see Text box 2.1). This chapter provides a concise description of the main assumptions used for constructing these greenhouse gas stabilisation profiles and the baseline used in this study. It also evaluates the emission reduction burden resulting from the baseline and the emission profiles. A more detailed description of the baseline emissions scenario, the CO₂e stabilisation profiles and their climate impacts can be found in (Eickhout et al., 2003).

1.1. Baseline scenario for the 1995 - 2100 period

A new baseline, called the Common POLES-IMAGE (CPI) baseline has thus been developed by RIVM and IEPE, in order to explore the implications of different options for the differentiation of future commitments, using both models. This baseline describes the development in the main driving forces (population and economic growth) and environmental pressures (energy, industrial and land-use emissions) for the 1995-2100 period. It is primarily based on the existing POLES reference scenario up to 2030 (see Criqui and Kouvaritakis, 2000) and extended to 2100 by using the IMAGE 2.2 model (IMAGE-team, 2001).

The baseline scenario describes a world in which globalisation and technology development continue to be an important factor behind economic growth, although not as strongly as for instance assumed in the IPCC A1b scenario (IMAGE-team, 2001; Nakicenovic et al., 2000). Economic growth is therefore assumed to reach a moderate level in almost all regions. As growth is in general faster in low income regions than in the high-income ones, the relative gap between regions decreases. However, for economic growth to occur, regions will need to have a sufficient level of institutional development and stability. In the CPI scenario it is assumed that in the next two decades, these conditions are not met in Sub-Saharan Africa – as a result of which this region clearly stays behind. However barriers to economic development in that region are supposed to be progressively removed and from 2025/2035 onwards it ‘takes off’, similarly to what happened to Asian countries in the last two decades.

The dynamics in the most important driving forces are indicated in Table 1¹. The UN long-term medium population projection have been used for the POLES model up to 2030 and for the IMAGE-TIMER up to 2100 – as implemented for the IMAGE B2 scenario (IMAGE-team, 2001). In this population scenario, the global population stabilises at a level of 9.5 billion by 2100.

¹ For comparability of the modelling results, all results are presented for an aggregate of 10 world regions. The composition of these regions is given in Appendix I.

Table 1: Main driving forces by region of the CPI baseline

	Population (in mln)			Per Capita Income (in PPP 1995\$/year)			Per Capita Income (growth rates 1995- 2025- 2025 2050)	
	1995	2025	2050	1995	2025	2050	1995- 2025	2025- 2050
Canada & USA	296	362	391	25604	42520	55757	1.7%	1.1%
Enlarged EU	505	499	450	17128	34534	50107	2.4%	1.5%
FSU	293	298	273	1747	5323	14750	3.8%	4.2%
Oceania	28	40	46	15469	30054	43397	2.2%	1.5%
Japan	125	121	111	41052	65270	90424	1.6%	1.3%
Latin America	476	690	800	3591	6779	12144	2.1%	2.4%
Africa	719	1346	1831	613	873	1761	1.2%	2.8%
ME & Turkey	219	378	483	3282	6371	12577	2.2%	2.8%
South Asia	1245	1865	2160	356	1560	4060	5.0%	3.9%
SE & E Asia	1798	2293	2439	1392	7404	16930	5.7%	3.4%
World	5706	7891	8984	4931	9052	14413	2.0%	1.9%

Source: IMAGE 2.2

The CPI baseline reflects historic developments in greenhouse gas emissions and the recent slowdown in the emission growth rate at the end of the last century, due to in particular the strong reductions in emissions in the Former Soviet Union and Eastern Europe following their economic downfall, as well as the reductions of the CO₂ emissions in China in the second half of the nineties. With the projected increase in population and income, primary energy use will continue to grow in almost all regions. Worldwide, primary energy use is expected to increase by about 75% in the 1995-2025 period and by another 40% in the 2025-2050 period and almost all of this growth occurs in non-Annex I regions. Oil continues to be the most important energy carrier until 2040. After 2040 both natural gas and coal take over this position.

As a result, energy-related carbon dioxide emissions increase strongly from 21.6 GtCO₂ in 1995 to 39.5 GtCO₂ in 2025 and 54.7 GtCO₂ in 2050 (see Table 1 and Figure 1) and continue to be the major source of greenhouse gas emissions. After 2050, a stabilising population levels slows down the further growth in carbon dioxide emissions. The share of non-Annex I in energy-related carbon dioxide emissions increases from 37% in 1995 to 45% in 2025 and 66% in 2050.

Using the land-use projections of IMAGE 2.2 (IMAGE-team, 2001), total greenhouse gas emissions are also be assessed – including land-use related emissions and non-CO₂ greenhouse gas emissions. In general, population growth and shifts to higher grade diets lead to an additional need for agricultural land in the first half of the century, despite improvements in agricultural production. Later, further productivity gains result in a surplus of agricultural land in high-income regions and it can be converted into forest land. As a result, carbon dioxide emissions from land-use increase slightly between 1995 and 2040 – but decrease afterwards. Most of the land-use related emissions origin from developing regions, in particular due to population growth and the share of non-Annex I in total anthropogenic greenhouse gas emissions is larger than that of energy-related CO₂ emissions, increasing from 48% in 1995 to 65% in 2025 and 71% in 2050. Methane and nitrous oxide emissions increase until 2060 after which they remain almost constant. Finally, industrial emissions, including in particular the high-GWP gas and process-related carbon dioxide emissions from cement production and feedstocks increase slowly over the whole century – but remain relatively small compared to other sources.

Table 2: Main outcomes of the CPI baseline

	Primary energy use (in PJ/year)			CO ₂ emissions (in GtCO ₂ /year)			GHG emissions (in GtCO ₂ -eq/year) *		
	1995	2025	2050	1995	2025	2050	1995	2025	2050
Canada & USA	91848	121405	128373	6.10	8.09	8.40	7.55	9.50	9.58
Enlarged EU	66070	83380	86702	4.36	5.10	5.32	5.38	6.00	6.05
FSU	37276	51960	57174	2.32	3.24	3.59	3.20	4.50	4.71
Oceania	4754	7955	9675	0.33	0.54	0.64	0.53	0.79	0.87
Japan	18866	22851	22480	1.26	1.48	1.41	1.37	1.58	1.51
Latin America	21763	49891	88932	1.18	2.89	5.11	2.33	4.54	7.00
Africa	19940	43168	79215	0.79	2.32	4.52	1.60	4.17	7.32
ME & Turkey	15065	41306	67132	1.06	2.85	4.36	1.35	3.69	5.73
South Asia	25175	62628	116495	0.97	3.79	7.46	2.11	5.54	9.44
SE & E Asia	71984	168736	251999	4.62	11.36	16.03	6.64	14.42	19.28
World	372742	653278	908176	22.99	41.65	56.83	32.06	54.74	71.48

* The greenhouse gas included are the 6 Kyoto gas: CO₂, CH₄, N₂O, SF₆, PFCs, HFCs. However, the F-gas are excluded from the regional figures as only global estimates are made. Thus the regional subtotals do not add up to the world total.

Source: IMAGE 2.2

The baseline scenario assumptions affect the emission profiles and burden sharing results in a number of ways. First of all, the baseline assumptions determine future land-use, which in turn affects the carbon cycle, notably the uptake of carbon from the atmosphere by the biosphere (terrestrial carbon uptake) as well as non-CO₂ greenhouse gas emissions (e.g. methane from animals and rice paddies; N₂O from fertiliser use in agriculture). Second, in the analysis of the emission endowment schemes, baseline assumptions about future regional population levels and per capita income and emission levels are important as they are used in the calculation of regional emission endowments (e.g. as participation and/or burden sharing criteria) under the future commitments schemes. Finally, the baseline assumptions determine the global and regional emission reduction burden, i.e. the difference between global and regional emission endowment and baseline greenhouse gas emission levels.

Figure 1: Greenhouse gas emission in carbon-equivalents by gas (top) and sector (bottom)

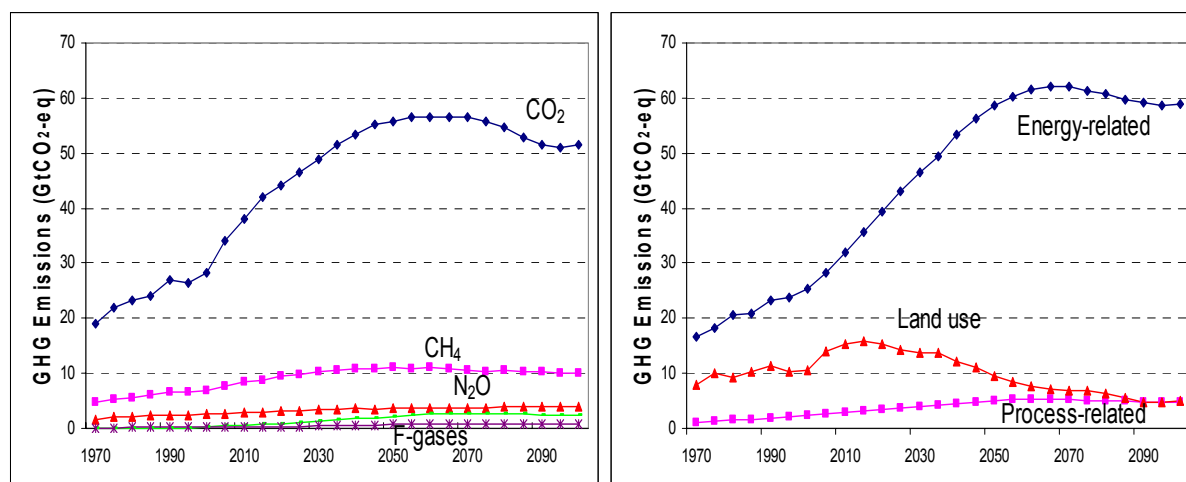

Source: IMAGE 2.2

1.2. Emission profiles for the stabilisation of greenhouse gas concentration at 550 and 650 ppmv

The IMAGE 2.2 model has been used to develop emission profiles up to 2100 for stabilising greenhouse gas concentrations at 550 and 650 ppmv in 2100 and 2150 respectively (see Figure 2). For this analysis the concept of CO₂e concentrations was used as it allows for expressing the contribution of all GHGs in CO₂e terms, in parallel with the Global Warming Potential concept (GWP) for emissions. Both concepts are explained in more detail in Text-box 1. The years for stabilisation of greenhouse gas concentrations were adopted from IPCC for CO₂ in order to allow for comparison between the stabilisation profiles for CO₂-only and for all GHGs².

For the construction of the profiles, an initial estimation of the contribution of non-CO₂ GHGs to the CO₂e concentration level had to be made³. Hence, the 550 and 650 ppmv CO₂e profiles, hereafter referred to as S550e and S650e respectively, were considered consistent with a stabilisation of the CO₂ concentrations at 450 and 550 ppmv CO₂, respectively. These CO₂ concentration profiles were used in the first phase of the project. In the second phase, the global CO₂e profiles have been used for a cost-optimal multi-greenhouse gas abatement analysis.

Figure 2: Global CO₂e concentration stabilisation profiles for S550e and S650e versus the CPI baseline scenario

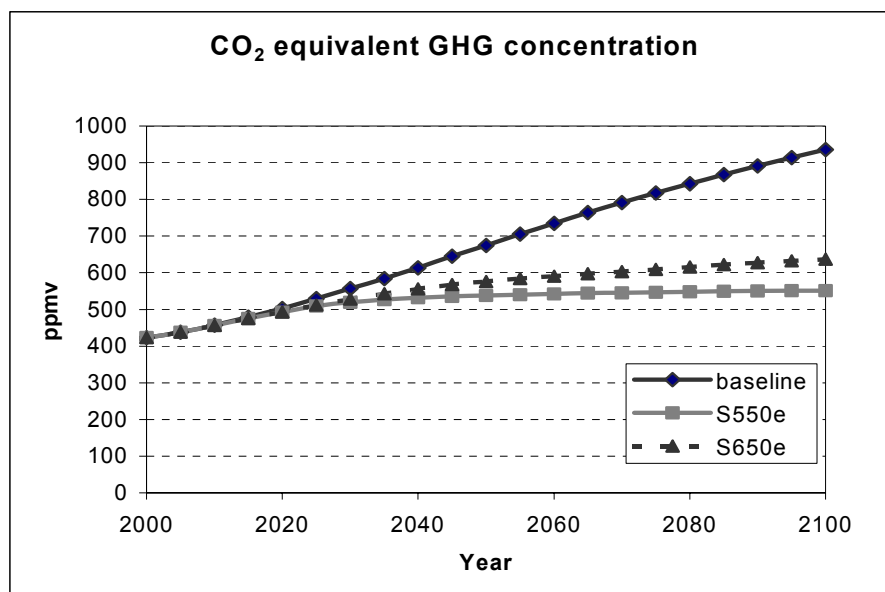

Source: IMAGE 2.2

The profiles up to 2010 take account of the Annex I Kyoto Protocol targets and, as far as the USA are concerned, of the greenhouse gas intensity target proposed by the US administration (-18% between 2002-2012) (de Moor et al., 2002; White-House, 2002a; White-House, 2002b). In the profiles, it is also assumed that about 80% of the excess

²Note that a stabilisation of GHG concentrations at 650ppmv in 2100 would result into an emission profile with higher emission levels in the first decades of this century, followed after by steeper reductions. This would imply smaller abatement efforts in the short term (2025) and larger abatement efforts in the long term (2050). However, as atmospheric GHG concentration levels would be somewhat above those of the S650e profile that stabilises in 2150 only, the temperature increase by 2100 would also be somewhat higher.

³ In the first phase of the study, this estimate was based on an assessment of the technical abatement potential for non-CO₂ GHG emissions. In the second phase, this contribution has been re-assessed on the basis of a cost-optimal multi-gas abatement strategy.

emission endowments (also referred to as ‘hot air’) of the Former Soviet Union and Eastern Europe are banked on the basis of revenue optimisation. Non-Annex I countries are assumed to follow their baseline emissions during this period. In the S550e and S650e profiles, CO₂ emissions continue to rise in the first decades of the simulation.

It has been assumed that for stabilising the concentration at 550 ppmv CO₂e, the growth of CO₂ emissions shifts from an annual 1.95% increase in 2010 to a 2% decrease in 2020. The CO₂ emissions after 2020 are determined by an inverse calculation with the IMAGE 2.2 model, determining the allowable emission levels resulting from a pre-described CO₂ concentration profile (i.e. 450 ppmv), while the mitigation of non-CO₂ greenhouse gas is supposed to result in a concentration of 100 ppmv CO₂e.

For stabilisation in the S650e profile, the CO₂ concentration is assumed to stabilise at 550 ppmv. Since the greenhouse gas emissions need to decrease to a lesser extent, the CO₂ emissions shift from an annual increase of 1.95% in 2010 to a 1.5% decrease not until in 2040. Again, the non-CO₂ GHGs account for 100 ppmv CO₂e, assuming the same mitigation options as in S550e. Because of higher temperatures in S650e than in S550e, the natural N₂O emissions are higher (IMAGE team, 2001). To compensate for these higher non-CO₂ emissions in S650e, higher emission reductions for the HFCs, PFCs and SF₆ have been assumed. Table 3 summarises the main characteristics of the S550e and S650e profiles.

Table 3: Main characteristics of the two constructed emission profiles

Characteristic	S550e	S650e
CO ₂ emissions in 2010 (GtCO ₂ per year)	37.58	37.58
Annual increase in 2010 (in %)	1.95	1.95
Target year of pre-described annual decrease	2020	2040
Level of annual CO ₂ decrease in that target year (in %)	2.0	1.5
Year of stabilisation	2100	2150
Level of CO ₂ concentration	450 ppmv	550 ppmv
Assumed levels of CH ₄ reductions (compared to baseline) ¹⁾	<ul style="list-style-type: none"> • Energy: 50% • Industry: 50% • Landfills: 100% • Sewage: 50% 	<ul style="list-style-type: none"> • Energy: 50% • Industry: 50% • Landfills: 100% • Sewage: 50%
Assumed levels of N ₂ O reductions (compared to baseline) ¹⁾	<ul style="list-style-type: none"> • Energy: 50% • Industry: 50% • Sewage: 100% • Fertiliser: 20% 	<ul style="list-style-type: none"> • Energy: 50% • Industry: 50% • Sewage: 100% • Fertiliser: 20%
Level of reduction for HFCs and PFCs in 2100 (reduction percentage compared to Sulphur emission levels)	50%	100% ²⁾
	Constant CO ₂ /SO ₂ ratio	Constant CO ₂ /SO ₂ ratio

¹⁾ Reached in 2025 for Annex I and 2040 for non-Annex I.

²⁾ Reductions in F-gas are higher in S650e to compensate for higher natural N₂O emissions resulting from a larger temperature increase.

Source: IMAGE 2.2

Text-box 1: CO₂-equivalent emissions and concentrations

CO₂-equivalent (CO₂e) emissions and concentrations are two ways to account for the impact of the different Kyoto greenhouse gases on the climate system. For CO₂e emissions of the Global Warming Potential (GWP) of each Kyoto gas have been used. The GWP is a measure of the relative radiative effect of a given substance compared to CO₂ integrated over a chosen time horizon (IPCC, 2001). Consequently, the GWP of CO₂ is by definition 1.0. The GWPs with a time horizon of 100 years from the Third Assessment Report (IPCC, 2001) are used here.

After its introduction, the GWP concept has been subject of continuous scientific debate on its adequateness to measure and combine the different effects on the climate system of the

different greenhouse gases and other radiative active substances, such as aerosols. The concept of GWPs is indeed very sensitive to the time horizon selected. The common 100 year time horizon tends to result in an overestimation of the contribution of short-lived greenhouse gases such as methane, and in an underestimation of long-lived gases like some HFCs and SF₆. However, at the same time the GWP concept is very convenient for adding up the contribution of different greenhouse gases in terms of CO₂e emissions, and no real alternative indicator has yet been established.

In this report, we also use the concept of CO₂e concentrations. This is a measure of the contribution of the various greenhouse gas to the radiative forcing in any given year. This measure is easy to interpret as well, but shows difficulties that are similar to those the GWP approach. However, one major advantage of CO₂e concentrations is the fact that this measure takes into account the different rates of removal from the atmosphere of various greenhouse gases. Eickhout et al. (2003) analysed – using the IMAGE 2.2 model – whether different contributions of the Kyoto gases to similar CO₂e emission profiles lead to different CO₂e concentrations and, hence, different climate impacts,. It was concluded that the uncertainty in the contribution of the different Kyoto gases to the CO₂e concentration levels indeed does have an impact on the eventual warming, but that this impact is relatively small, particularly when compared to the uncertainties stemming from the climate sensitivity.

The CPI baseline and the two emission profiles are plotted in Figure 3, which shows that stabilising CO₂e concentrations at 550 ppmv requires substantially larger and earlier global emission reductions than stabilising CO₂e concentrations at 650 ppmv.

Figure 3: Global emission profiles for stabilising greenhouse gas concentrations at 550 ppmv (S550e) and 650 ppmv (S650e) versus baseline emissions

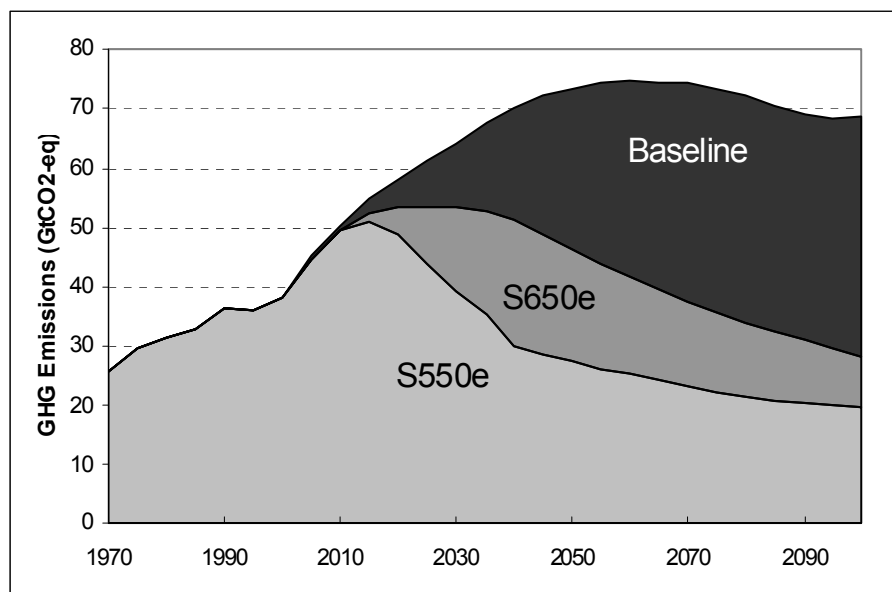

Source: IMAGE 2.2

For stabilising CO₂e concentration at 550 ppmv global greenhouse gas emissions would have to peak around 2015, while for the S650e profile this would be 2030. For S550e a further postponement of emission reductions is difficult if very steep global emission reductions (>2%/year) or an overshooting of the targeted concentration stabilisation levels are to be avoided. On the contrary for S650e there are many alternative pathways possible, including ones with global emissions peaking later (up to 2050) (Eickhout et al., 2003).

When the S550e and S650e profiles are compared with the WRE450 and WRE550 profiles (Wigley et al., 1996) for a stabilisation of the CO₂ only (as used in the IPCC Third Assessment Report, see Table 4), it is clear that, due to the incorporation of the climate policies up to 2010 (including the Kyoto Protocol and the Bush Plan (White-House, 2002a; White-House, 2002b)), the profiles used here are in timing comparable to the “delayed response scenarios” of the WRE profiles, i.e. with the peak in emissions occurring in the latest part of the identified time-range.

Table 4: Conditions for stabilising CO₂ concentrations according to the WRE profiles

WRE CO ₂ Stabilisation profiles	Accumulated CO ₂ emissions 2001 to 2100 (GtC)	Year in which global emissions peak	Year in which global emissions fall below 1990 level
450	365 - 735	2005 - 2015	< 2000 - 2040
550	590 - 1135	2020 - 2030	2030 - 2100
650	735 - 1370	2030 - 2045	2055 - 2145
750	820 - 1500	2040 - 2060	2080 - 2180
1000	905 - 1620	2065 - 2090	2135 - 2270

Source: IPCC –TAR (2001)

1.3. Impacts on temperature

The IMAGE 2.2 model was used to calculate the greenhouse gas emission concentrations and resulting global averaged surface temperature increase in 2100 that result from both the CPI baseline and the two alternative stabilisation profiles. Under the baseline scenario, greenhouse gas concentrations are projected to increase to about 930 ppmv CO₂e by the end of the century, resulting into a temperature increase of already over 3°C. This value results from the assumption of a medium climate sensitivity, which is defined as the equilibrium global-mean surface temperature increase resulting from a doubling of CO₂e concentrations.

The IPCC estimates the range of the climate sensitivity between 1.5 and 4.5°C, with a medium value of 2.5°C (IPCC, 2001). The uncertainty in the climate sensitivity is important in evaluating the compatibility of the stabilisation profiles with the EU 2°C target. Another uncertainty in projecting the temperature change resulting from the stabilisation profiles is the emission of sulphur emissions, which have a cooling impact. Here the assumption was made of a fixed ‘carbon to sulphur’ ratio, which results in SO₂ emission following the trend in the CO₂ profile.

Figure 4 depicts the range of the global-mean temperature increase up to 2100 resulting from the S550e and S650e profiles, while taking into account the uncertainty in the climate sensitivity. The difference in temperature increase between the two profiles only becomes apparent in the second half of the century. The reasons are delays within the climate system, and the fact that in the short-term CO₂ reductions also cause a reduction of the cooling effect of SO₂. Both in the case of the S550e and S650e profiles no equilibrium has yet been reached by 2100 and thus further warming is expected to take place afterwards.

Figure 4: Global-mean temperature increase since pre-industrial levels resulting from the S550e (left panel) and S650e (right panel) profiles for different climate sensitivity assumptions (1.5, 2.5 and 4.5).

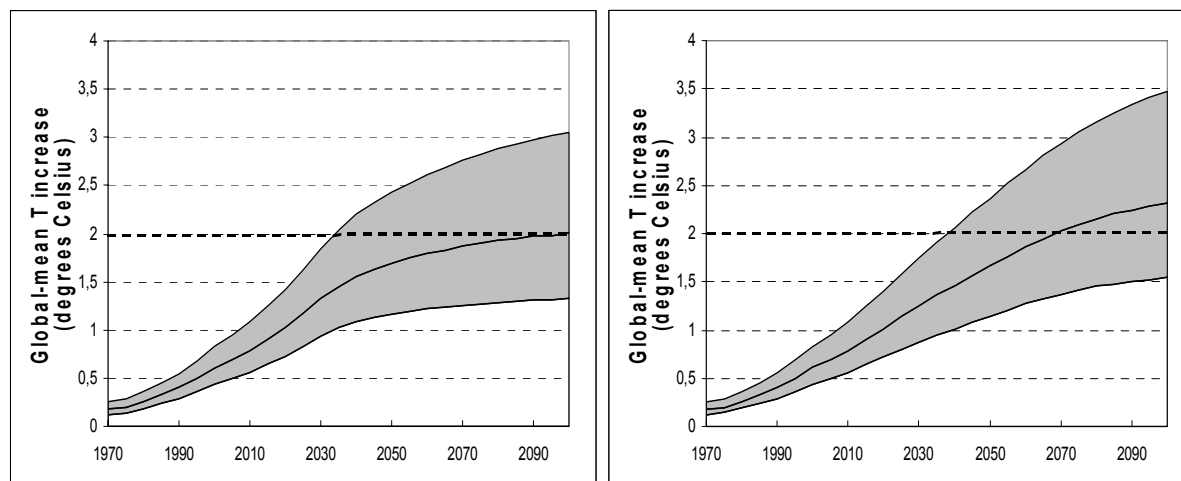

The upper lines indicate the temperature increase resulting from climate sensitivity =4.5; the lines in the middle climate sensitivity = 2.5 and the bottom lines climate sensitivity =1.5; the (flat) dotted line is the EU 2°C target.

Source: IMAGE 2.2

From the above analyses, it can be concluded that in principle the S550e profile can meet (or at least stay near) the maximum global temperature increase of the EU target for a median to low climate sensitivity. The S650e profile only does so in case the climate sensitivity is low. However, this profile is likely to overshoot the target by a considerable margin. In the case of a high climate sensitivity, the EU target will not be met in both profiles.

1.4. Implications for emission reductions

For both stabilisation at 550 ppmv and 650 ppmv CO₂e concentrations, substantial emission reductions from the baseline will be needed, particularly in the long-term.

- For the S550e profile, global energy- and industry related greenhouse gas emission levels in 2025 can still increase to about 20% above 1990 levels but this implies already a substantial emission reduction of 30% compared to baseline levels. For S650e the reduction compared to the baseline is smaller, but still significant at around 15%.
- In 2050 for S550e emissions have to be reduced strongly, not only compared to baseline level (ca. 65%), but also compared to 1990 levels: about 15%. In contrast, for S650e, the greenhouse gas emissions levels can still be 50% above 1990 levels by 2050. Compared to the baseline, they need however to be reduced by about 35%.
- By the end of the century, both stabilisation profiles for S550e and S650e imply global emissions to be substantially reduced compared to the baseline, by about 70% and 55% respectively. However, if compared to 1990, this implies a reduction of 30% for S550e, and stabilisation at 1990 levels for S650e.

Figure 5 presents the percentage change in energy- and industry related greenhouse gas emission levels required under the S550e and S650e profiles compared to both the CPI baseline and the 1990 level for the years 2025, 2050 and 2100. These emissions are used below in the analysis of the different climate regimes. It has to be noted that these levels are different from the reductions indicated in Figure 3, because of the exclusion of land-use change related emissions. In fact, the reduction in emissions from land-use change in the

baseline allows for relatively smaller future reductions in energy- and industry related greenhouse gases.

Figure 5: Global Energy- and Industry related greenhouse gas emissions reduction efforts for stabilisation at 550 ppmv (left panel) and 650 ppmv (right panel) CO₂e levels.

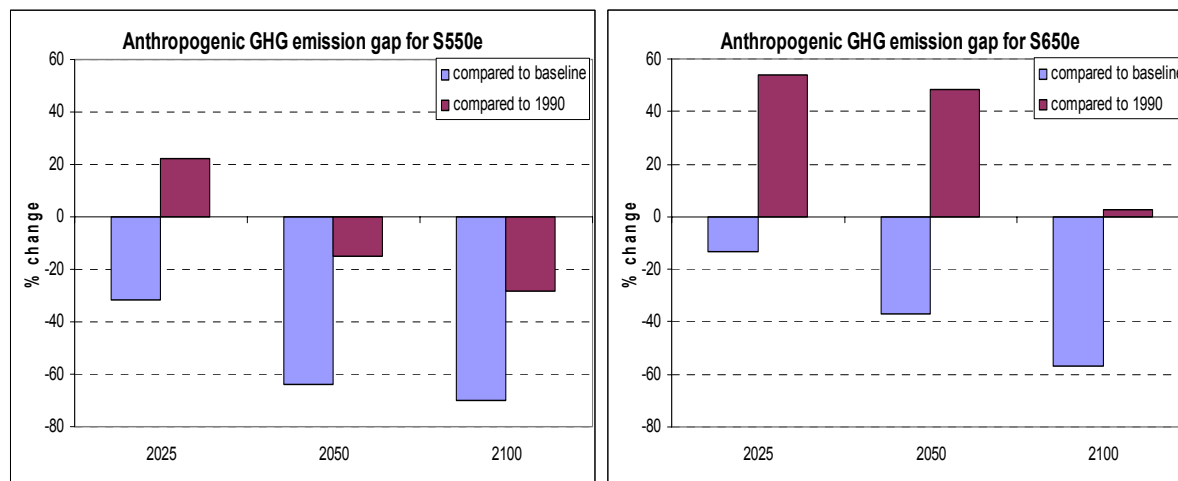

Source: IMAGE 2.2

1.5. Conclusions

- The continuation of non-constrained greenhouse gas baseline emissions leads to a global temperature increase of over 3°C over pre-industrial levels by 2100, which is well beyond the EU temperature target of 2°C.
- This EU climate policy objective might be met under both a profile for stabilising CO₂e emissions at 550 and 650 ppmv. However, for the S550e this will be the case for a low to medium estimate for the climate sensitivity. The S650e profile will meet the 2°C objective only if the climate sensitivity is at the low end of the uncertainty range. A medium value for the climate sensitivity would result into an increase of already 2.3°C by 2100, with further temperature increase thereafter. Therefore, this profile is likely to overshoot the EU target.
- Stabilising CO₂e concentrations at 550 ppmv requires substantially larger and earlier global emission reductions than stabilising at 650 ppmv. The emissions profiles corresponding to S550e and S650e peak by 2015 and 2030 respectively. For S650e different pathways allowing emission to peak later are possible; for S550e a further delay would result into very steep reductions after 2025 and/or a temporary overshooting of the 550 ppmv level.

2. A review and selection of the approaches to international commitment schemes

The abundant literature on greenhouse gas emission reduction targets and international equity shows that it is possible to identify many different approaches to international commitments. These approaches can be characterised according to various dimensions of international climate regimes (see Berk et al., 2002, Blanchard and al. 2000). One of the goals of the first phase of the 'Greenhouse gas Reduction Pathways' study has been to identify the key approaches to be considered and then to perform a preliminary economic assessment.

2.1. The dimensions of international commitment schemes

When dealing with the design of an international architecture for climate policies, a series of questions must be considered. They successively concern the proper definition of the problem, the principles to be invoked, the way targets are set, the timing for participation of the different Parties etc.

- *Problem definition (burden sharing or resource sharing)*: The climate change problem can be defined as a pollution problem or as a resource sharing problem. These different approaches have implications for the design of climate regimes. In the first approach, the burden sharing will focus on defining who should reduce or limit his pollution and how much; in the latter, the focus is on *who* has *what* user rights and the reduction of emissions will be in line with the user rights.
- *Emission limit*: Emission endowments can either be defined top-down, by first identifying globally allowed emissions and then applying rules for allocating the overall reduction effort needed, or instead in a bottom-up way by allocate emission endowments among Parties, without a predefined overall emission profile. In the top-down approach the question of adequacy of commitments is separated from the issue of burden differentiation. In the bottom-up approach, the two are dealt with at the same time.
- *Equity principles*: Equity principles refer to more general concepts of distributive justice or fairness (see e.g. Rose (1998); Banuri et al. (1996)). In the literature, many different categorisations of equity principles can be found (see Banuri et al., (1996); Rose(1998); Ringius et al. (1998)). Important equity principles for the purpose of characterising the approaches explored are (e.g., den Elzen et al. (2003a):
 - *egalitarian*: each human being has an equal right to use the atmosphere
 - *sovereignty / acquired rights*: all countries have an equal right to use the atmosphere; current emissions constitute a *status quo* right
 - *responsibility / polluter pays*: the greater the contribution to the problem, the greater the share in the mitigation / economic burden
 - *capability*: the greater the capacity to act or ability to pay, the greater the share in the mitigation / economic burden

The latter principle can be considered to also embrace the *basic needs* principle, when it is assumed that the capability principle allows for exempting countries from burden sharing to allow for fulfilling their basic development needs.

These general equity principles need to be distinguished from specific rules or formulas for burden sharing or emission quotas endowment, and from equity criteria or indicators (Ringius et al., 1998; Ringius et al., 2002; Rose, 1992). Rules for burden sharing or emission quotas endowments specify how the equity principle can be interpreted and applied in the

context of greenhouse gas emission control. Equity criteria or indicators further specify the way rules for burden sharing are to be operationalised.

- *Participation (thresholds / timing)*: Another dimension is that of the degree of participation: *who* should participate in sharing the burden and *when*? This issue concerns discussions on both the type of thresholds for participation and on the threshold level or timing. It is thus assumed that there is no need for all Parties to participate in the same way.
- *Type of commitment*: The approaches for the differentiation of commitments can either pre-define the endowment of emissions over time or make the endowment dependent on actual developments in the level of economic activity, population or emissions. In ex-ante analysis this results in *baseline dependent* endowment schemes. The level of dependency on actual developments can be limited, as in the case of the per capita convergence approach (dependent on population only), or important, as in the case of the multi-stage approach (dependent on population, income and emissions only).
- *Form of commitment*: The form of the commitment of each Party can be identical for all, as in the binding emission targets of the Kyoto Protocol, but also be defined in differentiated ways (see e.g. Baumert et al. (1999); Claussen et al., 1998; Philibert and Pershing (2001)). In place of *absolute targets*, commitments may also be defined as *relative* or *dynamic targets*, such as a reductions in energy or carbon intensity levels, or in terms of *policies and measures*. There is also the option of *non-binding commitments*.

A way of structuring the analysis of these different approaches is looking at the way the broadening of the participation to developing countries could take place. Berk and den Elzen (2001) have indicated that the development of the international climate regime could take two different directions:

- incremental regime evolution, i.e. a gradual expansion of the Annex I group of countries adopting binding quantified emission limitation or reduction objectives under the UNFCCC;
- or structural regime change, i.e. the adoption of a regime defining the evolution of emission endowments for all Parties over an extended time period.

The first approach would mean a gradual extension of the present Kyoto Protocol to differentiate the obligations of various Parties under the Convention. It could be based on ad-hoc criteria, or on pre-defined rules for both participation and differentiation of commitments. This type of regime we call '*Increasing participation*'. In an increasing participation regime, the number of Parties involved and their level of commitment gradually increase according to pre-defined rules for participation, like per capita income or per capita emissions. This kind of regime can be based on either one threshold for participation, or developed into a so-called Multi-Stage Approach by extending the number of stages or levels of participation for groups of countries.

The second approach would be a shift away from the present approach towards a regime that – in absolute or relative terms – pre-defines the endowments for all Parties and their evolution over a long-term period. This type of regime we call '*full participation*'.

When this dichotomy is combined with the form (same or different) and nature of the commitments (pre-defined or fixed versus path (baseline) dependent or dynamic) it is possible to describe the different approaches selected in the Greenhouse gas Reduction Pathways study and described in the following section as presented in Figure 6.

Figure 6: Categorisation of emission endowment schemes explored in the Greenhouse gas Reduction Pathways study

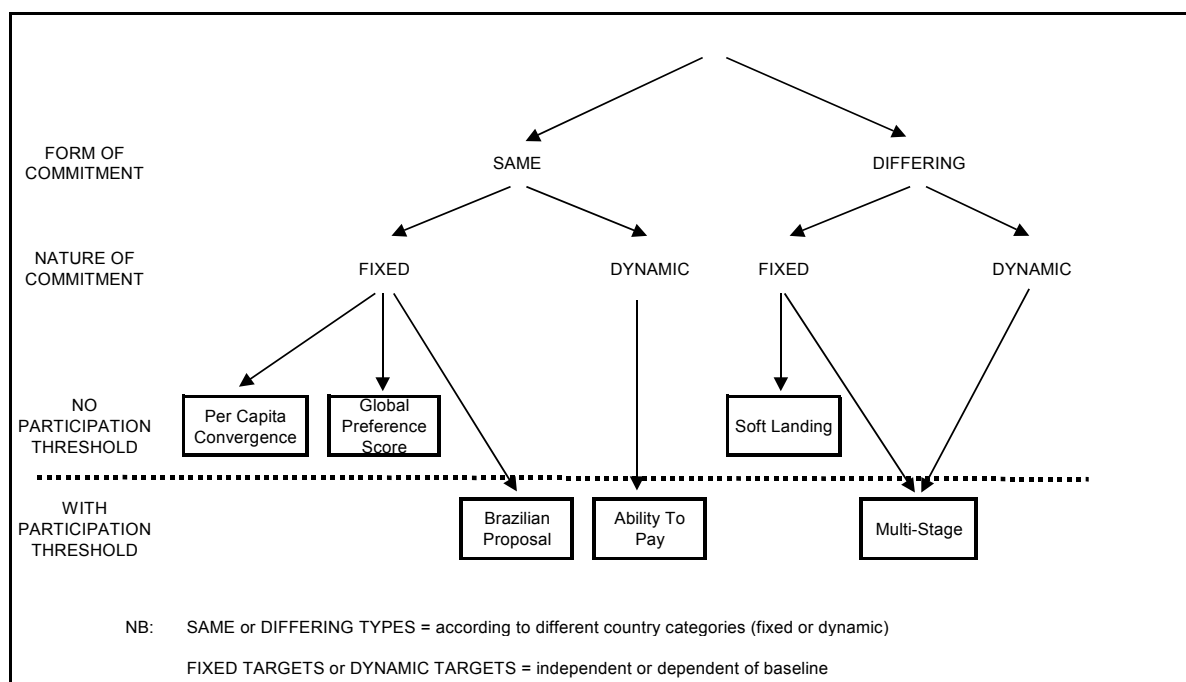

2.2. The selected endowment rules for the first phase of the Greenhouse gas Reduction Pathways study

For the first phase of the Greenhouse gas Reduction Pathways study, it was decided to select a limited number of international commitment systems, in order to provide preliminary assessments and to prepare for the final selection of the schemes to be fully tested by the different models. The proposals for differentiation have been identified according to different criteria, which combine the political relevance and the technical or economical feasibility. The six selected schemes are the following:

1. Brazilian proposal (BP)
2. Per Capita Convergence (PCC)
3. Multi-Stage approach (MS)
4. Soft-Landing approach (SL)
5. Global Preference Score approach (GPS)
6. Ability To Pay or Jacoby Rule (ATP)

1. Historical contribution to Climate Change (the Brazilian proposal)

During the negotiations on the Kyoto Protocol, Brazil made a proposal to link the relative contribution of industrialised parties to their relative contribution to the global mean temperature increase (UNFCCC, 1997). Since the adoption of the Protocol the proposal is under consideration of the Subsidiary Body for Scientific and Technological Advice of the UNFCCC for evaluation of its methodological aspects.

2. *Per Capita Convergence*

This approach, has been initially developed and promoted by the Global Commons Institute under the term Contraction and Convergence (Meyer, 2000). It defines emission quotas on the basis of a convergence in per capita emissions, under a contracting global greenhouse gas emission profile. In such a convergence regime, all countries participate with emission endowments converging to equal per capita levels over time.

3. *Multi-Stage approach*

The Multi-Stage Approach consists of a system to divide countries into groups with different levels of responsibility or types of commitments. The approach results in a gradual increase over time of the number of countries involved and their level of commitment according to participation and differentiation rules. These are based on criteria such as per capita income or per capita emissions. The approach was first developed by Gupta ((Gupta, 1998); Gupta et al, 2001) and later elaborated into a quantitative scheme by M. den Elzen et al (den Elzen, 2002; den Elzen et al., 1999) and Berk and den Elzen (2001).

4. *Soft Landing approach*

This method has been first proposed by P. Criqui and N. Kouvaritakis (respectively IEPE and IPTS) and a complete scenario has been described in Blanchard et al. (2001)). It proposes a scheme for a progressive stabilisation of emissions in non-Annex I countries, with a timing and level of commitment that is differentiated on the basis of per capita emissions and per capita income levels, as well as on their population growth. Annex I countries keep reducing their emissions according to a Kyoto-type trend.

5. *Global Preference Score approach*

This rule has been elaborated by U. Bartsch and B. Muller (2000). It combines a grandfathering entitlement method and a per capita approach. A 'Preference Score Share' to be reached by each country is calculated by adding the relative emissions shares of each method weighted by the share of world population that is assumed to prefer the first or the second approach (basically Annex I countries versus non-Annex I countries).

6. *Ability To Pay or Jacoby rule*

This rule has been elaborated at the MIT Joint Programme on the Science and Policy of Global Change by H. Jacoby et al. (Jacoby H.D., Schmalensee R., Wing S.L., 1999), and is also known as the "Jacoby rule". It consists of a set of rules for progressively integrating non-Annex I countries into a system of global emissions reduction and defining subsequent levels of reduction commitments for meeting long-term climate targets basically depending on countries' GDP per capita levels.

2.3. Characterisation of the six selected approaches

The dimensions explored above in 2.1 can be used in order to identify the main characteristics of the six approaches selected for the first phase of the study and listed above in 2.2. This provides the following observations, also summarised in Table 5:

- The *Brazilian proposal* is clearly based on the responsibility principle, but could also include the capability principle by including a income threshold for participation.
- The *Ability To Pay* and *Soft landing* approaches are based on the capability principle, although the *Soft Landing* approach also incorporates some elements of responsibility.
- The *Per Capita Convergence* and *Global Preference Score* approaches both combine the egalitarian and acquired rights approaches, leaving aside the responsibility and capability principles.

- The *Multi-Stage* approach is mainly based on a combination of the responsibility and capability principles, but can also include elements related to the egalitarian principle, e.g. by using per capita emissions levels as burden sharing key.
- The *Per Capita Convergence* and *Global Preference Score* approaches are the only ones that are based on the global commons paradigm and resource sharing concept; the other approaches are based on the pollution problem paradigm and burden sharing concept.
- The *Per Capita Convergence*, *Global Preference Score* and *Multi-Stage* approaches are based on a top-down approach to defining emission endowments. The other approaches are more bottom-up in character, but can be adjusted to a top-down approach.
- The *Per Capita Convergence*, *Global Preference Score* and *Soft landing* approaches pre-define the endowment of emissions largely irrespective of future developments. In ex-ante analyses, emission endowments in the Multi-stage and the Jacoby rule approaches are most strongly influenced by baseline assumptions.
- The *Multi-Stage* approach is the only approach that implies a progressive involvement of different country categories, with different forms of commitments and in a dynamic framework based on participation thresholds.

Table 5: A comparison of differences approaches to international burden differentiation

Dimensions	Multi-Stage	Soft Landing	Per Cap Conv.	Global Pref. Score	Brazilian proposal	Ability to Pay
Equity principles						
• Responsibility	X				X	
• Capability	X	X			(X)	X
• Egalitarian	(X)		X	X		
• Acquired rights			X	X		
Problem definition						
• Pollution problem	X	X			X	X
• Global commons issue			X	X		
Emissions limit						
• top down	X	(X)	X	X	(X)	(X)
• bottom up		X			X	X
Participation						
• Partial	X				(X)	X
• All	(X)	X	X	X	X	
Nature of Commitments						
• Pre-defined		X	X	X		
• Path dependent	X				X	X
Form of Commitment						
• Equal			X	X	X	X
• Differentiated	X	X				

X= applicable; (X) = partly applicable

Source: (Berk et al., 2002; den Elzen et al., 2001)

2.4. Outcomes of the different approaches assessed in the first phase of the study

In the first phase of the 'Greenhouse gas Reduction Pathways' study, the impact assessment of the different approaches has been performed in a CO₂-only framework and for two concentration stabilisation scenarios: 450 and 550 ppmv CO₂, respectively corresponding to S550e and S650e in a multi-gas approach. Although preliminary, this assessment has allowed to thoroughly describe the dynamics in emission endowments for the different world regions and thus to prepare the selection and in-depth analysis of a more limited number of approaches.

2.4.1. The commitment schemes and resulting endowments

The in-depth examination of the different international commitment schemes has allowed to identify the key parameters that had to be defined in order to attain a practical implementation of each approach. Sensitivity studies then allowed to develop a reference value for these parameters and the resulting international endowments have finally been compared for different time horizons and emission profiles. Table 5 provides an example of the results for five approaches, in the 450 ppmv CO₂-only case and for the year 2050. For a detailed description of the analysis we refer to den Elzen et al. (2003a). In this table, values higher than 100 % correspond to negative emission endowments and indicate extreme – and probably unrealistic – cases, where a region, due to its large historical contribution to temperature change, would necessarily have to buy quotas, even if its emissions were brought down to zero.

Table 6: 2050 regional endowments for different approaches, in the 450 ppmv CO₂-only profile (corresponding to S550e)

2050 Regions	PCC		BP		MS		GPS		ATP	
	Edowment compared to		Edowment compared to		Edowment compared to		Edowment compared to		Edowment compared to	
	Reference	1990	Reference	1990	Reference	1990	Reference	1990	Reference	1990
North America	-92%	-89%	-89%	-86%	-91%	-88%	-84%	-80%	-80%	-76%
Enlarged Europe	-84%	-85%	-110%	-110%	-82%	-83%	-73%	-74%	-79%	-80%
CIS + Oth. Eur.	-89%	-88%	-98%	-98%	-88%	-87%	-80%	-80%	-81%	-80%
Oceania	-90%	-78%	-110%	-121%	-90%	-78%	-87%	-73%	-89%	-76%
Japan	-86%	-86%	-84%	-83%	-84%	-84%	-75%	-74%	-80%	-80%
Latin America	-75%	16%	-100%	-100%	-81%	-12%	-77%	6%	-89%	-47%
Africa	-20%	277%	-16%	296%	-21%	273%	-51%	132%	-22%	267%
Mid. East & Turkey	-83%	-19%	-73%	30%	-85%	-29%	-85%	-29%	-85%	-27%
South Asia	-63%	312%	-39%	576%	-47%	484%	-69%	241%	-58%	360%
South East & East Asia	-75%	5%	-72%	18%	-78%	-6%	-73%	14%	-82%	-24%

Source : FAIR model

The generic features of the different endowment schemes can be synthesized as follows:

- *Per capita Convergence:*

Per Capita Convergence not only implies emission reduction efforts from Annex I regions, but also from many non-Annex I regions before 2025. Conversely, some regions may experience hot air (mostly Africa and South Asia). The occurrence and level of hot air is of course dependent on the stringency of the climate target and convergence year. These factors have the greatest impact on the distribution of emission endowments, while the impact of the *population cut-off year* is limited.

- *Brazilian Proposal:*

Burden sharing rules based on the regions' contribution in realised global temperature increase result in much lower per capita fossil CO₂ emission endowments for Annex I regions than for non-Annex I regions due to their larger contribution in realised global temperature increase than per capita fossil CO₂ emissions. However, results are dependent on the historical time-horizon. If only contributions after 1950 or 1990 were accounted for, then the results would change significantly.

In the case of a stringent climate target the Brazilian Proposal approach combined with an income threshold leads to negative emissions endowments for the Annex I regions and Latin America (due to high land-use emissions). The Brazilian Proposal approach is therefore generally particularly unattractive for the Annex I regions and for Latin America.

- *Multi-stage (MS):*

In a Multi-Stage regime, using per capita contribution to fossil CO₂ emissions as burden sharing key tends to result in a convergence of per capita fossil CO₂ emissions amongst Annex I and non-Annex I regions in the long-term (by 2050).

If instead of a per capita income threshold, world average per capita fossil CO₂ emissions were used as an additional threshold for participation, low income non-Annex I regions (notably East Asia, South Asia and Africa) would need to participate earlier. This would be to the advantage of both Annex I regions and Latin America and Middle East/Turkey.

- *Global Preference Score:*

The Global Preference Score approach generally provides larger endowments to Annex I regions than is Per Capita Convergence as it is a compromise between a flat rate reduction (grandfathering) and Per Capita Convergence. In contrast to Per Capita Convergence, it does not lead to a full convergence of per capita emissions over time. The GPS outcomes are less sensitive to a change in parameter settings than Per Capita Convergence.

- *Ability To Pay / Jacoby Rule:*

The regional emissions endowments under the Jacoby rule approach highly depend on the assumptions adopted for the per capita welfare trigger. In general, a low welfare trigger is less attractive for all non-Annex I regions, and evidently, more attractive for the Annex I regions.

2.4.2. Key conclusions

The key conclusions of the first phase of the Greenhouse gas Reduction Pathways study thus stand as follows:

- In the long-term (2050) and under a low emission profile for stabilising CO₂-only concentrations at 450 ppmv, in most approaches emission endowments of Annex I regions should be reduced by more than 40% compared to their 1990 emission levels. This represents reductions from baseline of more than 70%.
- Under the Baseline, the emission profile for stabilising CO₂-only at 450 ppmv does not allow for using an income threshold level of more than 50% of 1990 average Annex I per capita income (expressed in Purchasing Power Parity dollars); a higher income threshold results in an overtaking of the global CO₂ emission profile.
- In order to meet the emission profile for stabilising CO₂-only at 450 ppmv, major non-Annex I regions (East Asia and South Asia) need to start participating in global emission reduction before the middle of this century, irrespective of the emission endowment approach and type of threshold chosen.
- Non-Annex I regions thus will have to start participating in global emission reduction at significant lower per capita income and emission levels than Annex I under the Kyoto Protocol.
- In the short-term (2025), the income threshold level for participation used implies that the burden-sharing key used mainly affects the distribution of the burden among the Annex I regions.
- Results found are very sensitive to the assumptions, in particular: the burden-sharing key, participation threshold and convergence year. Therefore, it is hard to draw general statements on the regional impacts of each approach. However, regions that rank much higher than average on one burden-sharing indicators like

per capita emissions, emissions intensity or per capita income are particularly affected when this indicator is chosen.

- The attractiveness of a regime also depends on the time-horizon chosen. For example, the Multi-Stage reference case is relatively attractive for the Middle-East, but in the long-term becomes the least attractive approach for that region.
- For Annex I regions, regimes without thresholds for participation generally provide larger endowments, but the burden sharing keys or emission quotas endowment rules can have significantly different implications for them.
- There are clear divergences amongst high and low-income non-Annex I regions. High-income non-Annex I regions have a clear interest in an early participation of the low-income non-Annex I regions, although the burden sharing key still plays a significant role.
- In the short-term, for the least developed non-Annex I, non-participation is more attractive than participation unless their allowable emission levels are larger than their baseline emissions (hot air), like for the Per Capita Convergence and Global Preference Score. In the long-term, however, the Brazilian Proposal and Multi-Stage approaches become more attractive compared to Per Capita Convergence and Global Preference Score.
- In the case of a high threshold for participation, non-Annex- I regions experience a strong shift from their baseline immediately after entering the burden sharing regime. This is problematic as it may result in difficulties in rapidly meeting full compliance.
- All cases result in a convergence in the per capita emissions for Annex I and non-Annex I. However, in the Brazilian Proposal case Annex I per capita emissions endowments decrease below non-Annex I per capita emissions endowments, whereas for Global Preference Score, no full convergence is reached.

The low emission profile (450 ppmv CO₂-only or 550 ppmv CO₂e) appears to be a strongly constraining case, in particular when it is tested for CO₂ emissions only. In particular the Soft Landing case which has been initially designed to provide a progressive and relatively soft constraint for all regions turns into a very hard constraint for Annex I countries under the 450 ppmv CO₂-only case. The difficulty in developing a balanced case along the soft Landing lines may to some extent be considered as an indication of the stringency of the constraint.

It has also to be underlined that under such a stringent case, all cases with a threshold for participation, should incorporate a relatively low level threshold (less than 50 % of Annex I 1990 per capita GDP level) as the early participation of all developing countries turns to be unavoidable.

The 2025 horizon, which is relatively near to the 2010 starting point for the analysis of the commitment schemes is in many cases a too short time-horizon to clearly differentiate the impacts of the selected schemes. In many cases commitment profiles show strong decreases shortly after this date: in many cases the 2030 horizon already takes into account a large part of the adjustment to be realised in 2050.

When the 2050 time horizon is considered, most schemes show quite comparable profiles in most regions. Only the Brazilian Proposal does result in significantly different profiles, in particular with negative endowments for Europe, Oceania and Latin America.

3. The long-term endowment schemes: design, key parameters and resulting endowments

The first phase of the 'Greenhouse gas Reduction Pathways' study allowed in particular to identify the 'Full Participation' and the 'Increasing Participation' or 'Multi-Stage' approaches to international commitment schemes as representing key alternatives for the design of climate regimes. This chapter describes and analyses the implications of a set of five detailed schemes: two are based on the Per Capita Convergence in emissions scheme already explored in Chapter 2 above and represent the 'Full Participation' framework; the three other are newly developed schemes belonging to the branch of the 'Multi-Stage' approaches; based on earlier work by RIVM and in one case incorporating elements of the IEPE - ICCS 'Soft-Landing' approach, they represent simpler solutions than the original ones (Berk and den Elzen, 2001).

3.1. Key assumptions for the Per Capita Convergence and Multi-Stage cases

3.1.1. Two Per Capita Convergence cases: convergence in 2050 and in 2100

The assumptions for the two Per Capita Convergence cases are indicated in Table 7. In the original Contraction and Convergence approach of the GCI, which is based on a non-linear convergence formula, the actual degree of convergence in per capita depends on the rate of convergence selected. This rate of convergence determines whether most of the per capita convergence takes place at the beginning or at the end of the convergence period.

In the Per Capita Convergence regime explored here, a linear convergence has been assumed. Another important parameter in the approach is connected to the issue of population growth. GCI has indicated that the approach may be combined with the option of applying a cut-off year after which population growth is no longer accounted for. In our definition, the approach is applied without any cut-off year, and is thus based on population projections from the CPI baseline scenario.

Table 7: Two alternative cases of per capita convergence (PCC) approach for the S550e profile. Note: these assumptions are the same for the S650e cases

<i>Key parameters</i>	<i>PCC2050</i>	<i>PCC2100</i>
Year of convergence	2050	2100
Rate of Convergence	Linear	Linear
Cap population	Not applied	Not applied

3.1.2. Three simplified Multi-Stage schemes to emission commitments

The section below provides a synthetic description of the three Multi-Stage schemes defined in the 'Greenhouse gas Reduction Pathways study': MS1, MS2 and MS3. All of these endowment schemes are in particular characterised by three consecutive stages for the commitments of non-Annex I countries:

- Stage 1. no commitment,
- Stage 2. carbon intensity targets,
- Stage 3. participation to burden sharing.

Also common to the three Multi-Stage approaches is the indicator of Capacity-Responsibility that triggers the entry into Stage 2 as well as the entry into Stage 3 in MS2. It is a mixed indicator drawing from Article 3.1. of the UNFCCC mention of the “*common but differentiated responsibilities and respective capabilities*” that should be taken into account in defining the appropriate action of the different Parties.

As shown in Table 8, the Capacity-Responsibility index is in practical terms defined as the sum of the per capita income (expressed in k99€/cap), which relates to the capacity to act, and of the per capita CO₂e emissions (expressed in tCO₂/cap), which reflects the responsibility in climate change. Because it combines variables of a different nature, this composite index should in principle be normalised or weighted. It happens, however, that in this particular case a one-to-one weight produces fairly satisfactory results. At any date, the Capacity-Responsibility indicator index can thus be simply computed for each country or region as the sum of its GDP and total greenhouse gas emissions, divided by its population.

Table 8: The Capacity-Responsibility index, regions ranked by decreasing number in 2000

	2000			Baseline - 2025		
	Per Capita GDP (1000 €, PPP)	+ Per Capita Emissions (tCO ₂ e)	= CR Index*	Per Capita GDP (1000 €, PPP)	+ Per Capita Emissions (tCO ₂ e)	= CR Index
USA	32	26	58	46	27	73
Canada	26	21	47	38	21	59
Oceania	19	17	35	31	17	48
Japan	25	10	35	38	12	50
Enlarged EU	19	10	29	33	12	45
CIS + Other Europe	5	10	16	12	16	28
Middle East	5	6	12	10	8	18
Latin America	7	5	11	11	6	17
South East Asia	4	3	8	10	6	16
China	4	4	8	11	7	18
Africa	2	2	4	3	3	5
India	2	2	3	6	4	10
Rest South Asia	2	1	3	3	2	5

* Index may differ from the sum due to independent rounding

Source: POLES model

While resulting from a pragmatic approach, this indicator shows good ‘screening’ properties, in the sense that it allows to identify in a satisfactory way the existing Annex I, as well as relevant country groupings for non-Annex I regions. The ranking of regions as it comes out from the 2000 index is modified in 2025 only for a limited number of cases. These exceptions are meaningful however as they reveal in particular the buoyant trends that are expected in China and in India. Figure 7 provides a picture of the trajectory of each POLES model region in a Capacity-Responsibility diagram, between 1990 and 2030. In this diagram, the diagonal lines indicate constant levels of the Capacity-Responsibility index.

Figure 7: The Capacity-Responsibility diagram and index, POLES regions 1990-2030

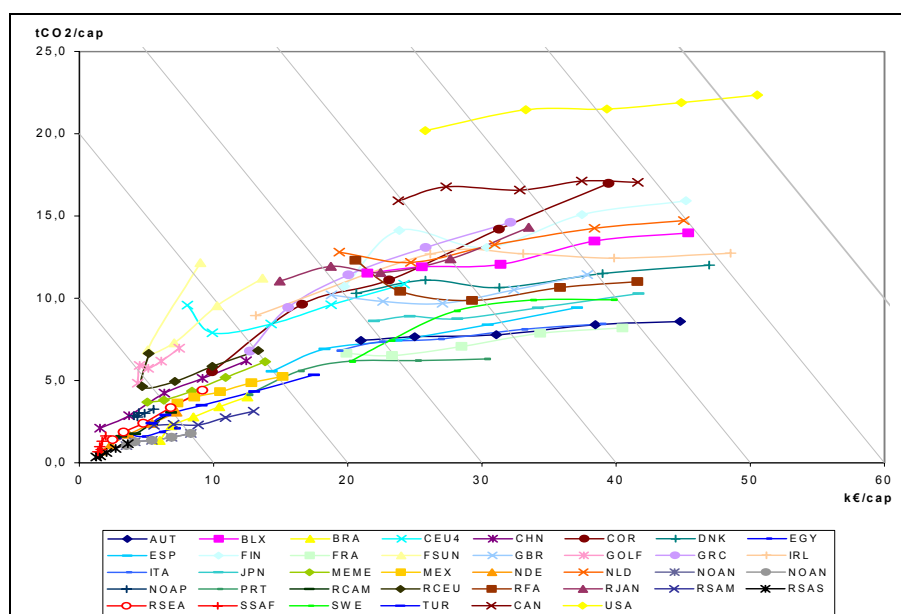

Source: POLES model

3.1.3. Hypotheses for the Multi-Stage cases in the S550e constraint

Table 9 provides an overview of the assumptions made in implementing the various Multi-Stage variants under the S550e profile. The background information for these assumptions, as well as a detailed sensitivity analysis for these parameters is described in detail in den Elzen et al. (2003).

Table 9: Assumptions for the Multi-Stage cases for the S550e constraint

Key parameters	Multi-Stage 1	Multi-Stage 2	Multi-Stage 3
Stage 1 No quantitative commitments			
Stage 2 Emission limitation targets:			
adoption of intensity targets	CR = 5	Same as MS1	Same as MS1
Participation threshold			
De-carbonisation rate /	Income-dependent	Same as MS1	prescribed
Stabilisation	intensity targets (*)		stabilisation path
Stage 3 Emission Reduction targets:	100% of world average	CR = 12	Stabilisation
Participation threshold	per capita emissions		period (TC=70)
Burden-sharing key	per capita emissions	Same as MS1	Same as MS1

(*) The Capacity-Responsibility index is defined as the sum of per capita income (expressed in PPP\$/cap.) and per capita CO₂e emissions (tCO₂/cap.yr).

(**) The de-carbonisation rate (in percentages), is a linear function of per capita income (PPP\$/cap): $a * \text{PPP}/\text{cap}$, $a = 0.33$, and using a maximum de-carbonisation rate of 3%

For all three Multi-Stage cases under the S550e profile the same first Capacity-Responsibility threshold of 5 is chosen: as a result all middle- and high-income non-Annex I regions – i.e. all non-Annex I regions except for South Asia and West- and East-Africa – participate in the emission limitation stage after 2012.

For the second participation threshold (emission reduction stage), the MS1 case assumes 100% of world average per capita emissions. This results into a gradual convergence of per capita emissions between Annex I and non-Annex I overtime. East Asia (China) plays a key role in the outcomes, as when it enters the emission reduction regime, its emissions

endowments are decreased considerably, relaxing the emissions reductions for the other participating regions. Therefore, East Asia's entry strongly determines the reduction efforts of the Annex I countries.

The assumptions for the MS2 case are the same as for MS1, except for the second threshold, which is now based on a second Capacity-Responsibility index set on CR = 12. Higher Capacity-Responsibility values mainly delay the participation of the East Asia region, and thereby increases the Annex I emissions reduction efforts. Lower Capacity-Responsibility values would imply the immediate participation of the middle- and high-income non-Annex I regions, especially Central America and East Asia, in the emission reduction regime after Kyoto.

The MS3 case differs from the previous MS1 and MS2 case with respect to the targets during the transition period. The de-carbonisation targets are there replaced by a prescribed slow-down in the emission growth, unto a final stabilisation. The length of the transition period is predetermined by a Transition Constant: the length of the transition is calculated by dividing the Transition Constant value by per capita emissions (in tCO₂/cap.yr) in the reference period. Here, a value of 70 was chosen for the constant as this results into a convergence in Annex I and non-Annex I per capita emissions by 2040 under the S550e profile: for instance, if the per capita emissions indicator amounts to 10, the transition period will be 7 years.

3.1.4. Assumptions for the Multi-Stage cases under the S650e constraint

Table 10 provides an overview of the assumptions made in implementing the various Multi-Stage variants under the S650e profile. All Multi-Stage cases again make the same assumptions for the following policy variables: i/ first participation threshold, ii/ linear de-carbonisation rate, and iii/ burden-sharing key. The values of the settings are different from those of the S550e profile. The first Capacity-Responsibility threshold level has been relaxed and set to 12, while the maximum de-carbonisation rate has been reduced to 2.5%/year, since early participation of non-Annex I regions and stringent greenhouse gas intensity improvements are not necessary anymore. This results in a sufficiently early participation of middle- and high-income non-Annex I regions in the emission limitation stage, while still leaving them some time in the emission limitation stage.

Table 10: Assumptions for the Multi-Stage cases for the S650e constraint

<i>Key parameters</i>	<i>MS1</i>	<i>MS2</i>	<i>MS3</i>
Stage 1 No quantitative commitments			
Stage 2 adoption of intensity targets			
Participation threshold	CR = 12	Same as MS1	Same as MS1
De-carbonisation rate / Stabilisation	Income-dependent intensity targets (*)	Same as MS1	prescribed stabilisation path
Stage 3 Emission reduction regime		CR = 20	Stabilisation period (TC=100)
Participation threshold	120% of world average pc emissions		
Burden-sharing key	per capita CO ₂ emissions	Same as MS1	Same as MS1

(*) The CR index is defined as the sum of per capita income (expressed in PPP\$/cap.) and per capita CO₂e emissions (tCO₂/cap.yr).

(**) The de-carbonisation rate (in percentages), is a linear function of per capita income (PPP\$/cap): $a * PPP/cap$, $a = 0.33$, and using a maximum de-carbonisation rate of 3%

For participation in the emission reduction regime, the MS1 case assumes a threshold of 120% of world average per capita (CO₂) emissions. This results into a convergence of Annex I and non-Annex I per capita emissions over time under the per capita emission

burden-sharing key. Under a higher level, non-Annex I regions per capita emissions would exceed the Annex I per capita emissions.

In MS2, the assumptions made are the same as for MS1, except for the participation threshold for the emission reduction stage, which is now based on a threshold of CR = 20. Lowering the Capacity-Responsibility threshold reduces the Annex I emissions reduction efforts, but results into a shorter emission limitation stage for non-Annex I regions. Higher Capacity-Responsibility values delays the participation of the middle-income non-Annex I regions, and lead to high Annex I emissions reduction efforts.

For the MS3 case under the S650e profile, we use a Transition Constant value of 100 (instead of 70 for the S550e profile) in order to extend the stabilisation period for the non-Annex I regions, and thereby reduce their reductions efforts under this profile. Example: If the per capita emissions indicator amounts to 10, the transition period would be 10 years. As the sensitivity analysis (next section) shows, the influence of different TC values is rather limited.

3.2. Regional endowments under the S550e constraint

3.2.1. S550e, reductions from Reference case to 2025 and 2050

Table 11 provides a synthetic view of the participation of the non-Annex I regions in the de-carbonisation and burden-sharing stage. Figure 8 shows the percentage change in the emission endowments relative to the 1990 emission level in the target-years 2025 and 2050 for the three Multi-Stage cases and the two Per Capita Convergence cases.

Table 11: S550e, participation of non-Annex I regions in the de-carbonisation and burden-sharing stage for the Multi-Stage cases.

Regions	Central America	South America	North Africa	West Africa	East Africa	South Africa	Middle East	South Asia	East Asia	South-East Asia
Entry to Stage 2	2012	----	2012	2055	2065	2012	----	2015	2012	2010
Entry to Stage 3										
Multi-Stage 1	2035	2012	2040	2060	2075	2030	2012	2045	2020	2035
Multi-Stage 2	2015	2012	2050	2100	2100	2060	2012	2050	2015	2030
Multi-Stage 3	2025	2025	2030	2085	2095	2030	2020	2045	2025	2030

Note 1: for each region, white-boxes indicate the earliest entry case, dark-grey the latest, and light-grey in between
 Note 2: South America and Middle-East directly enter in Stage 3

Figure 8: Change in the CO₂e emission endowments relative to 1990 for the Multi-Stage and Per Capita Convergence cases in 2025 and 2050, S550e

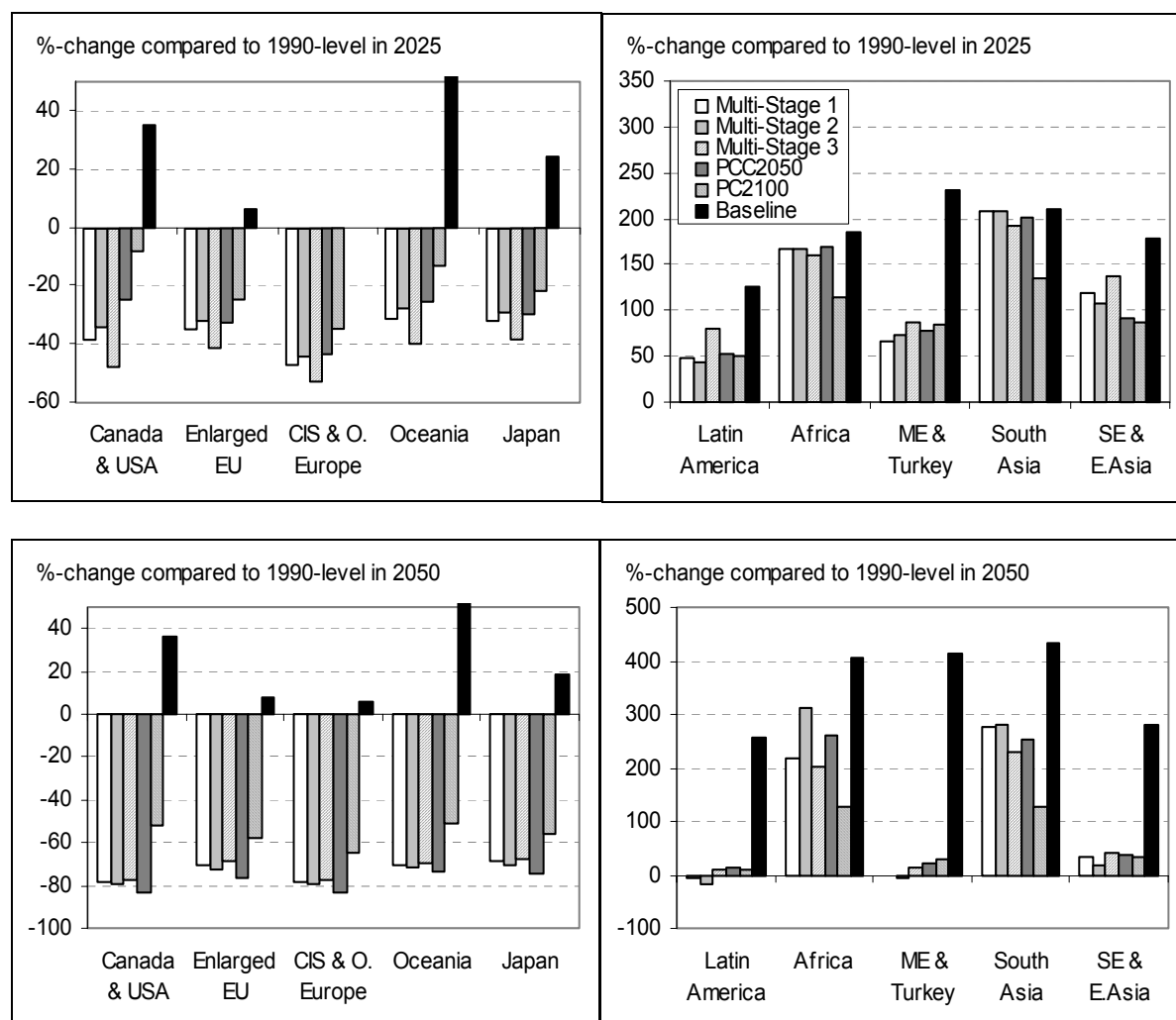

Source: FAIR 2.0 model (den Elzen, 2002; den Elzen and Lucas, 2003)

The key findings of this analysis of endowments in the S550e case can be summarised as follows:

Multi-Stage scenarios:

Emission limitation and Emission reduction stage

- For the emission limitation stage all Multi-Stage cases show an early participation of the non-Annex I regions, except for West- and East Africa (after 2050).
- For the middle- and high-income non-Annex I regions, MS2 leads to the earliest entry (immediately after 2012), whereas the MS3 case shows the latest entry. For the low-income non-Annex I regions, all three Multi-Stage cases show a late entry, especially for MS2 and MS3.

Emission endowments, short-term:

- For the Annex I regions, the MS2 case results into the largest endowments, whereas the MS3 case results in the smallest ones. This is a result of the earlier entry of middle- and high-income non-Annex I regions for MS2.
- The middle- and high-income non-Annex I region show an opposite pattern, while the endowments of low-income non-Annex I regions are close to the baseline emissions.

Emission endowments, long-term:

- The differences for the Annex I regions are small, as all Multi-Stage cases lead to small endowments. Also the middle- and high-income non-Annex I regions are submitted to limited endowments.
- For the low-income non-Annex I regions, the MS3 case results in the smallest endowments, due to the relatively low stabilisation path in the transition stage (stage 2).

Per Capita Convergence scenarios:

- The PCC2100 case results into substantially larger endowments for the Annex I regions than all other cases. The results of PCC2050 case are more comparable to the Multi-Stage cases.
- In the short-term, the PCC2050 case results in larger endowments for North America than the Multi-Stage cases, while for the other Annex I regions the differences are relatively small. The MS3 case results in the smallest endowments for the Annex I regions, while in the long-term the PCC2050 case results in lower endowments than the Multi-Stage cases.
- For the more developed non-Annex I regions (Latin America, Middle East & Turkey) the MS3 approach involves the least reductions.
- For the least developed non-Annex I regions (South Asia, Africa) the differences in results of the Per Capita Convergence and Multi-Stage cases are relatively large. The PCC2050 case generally does not result into larger emission endowments for the least developed regions. In particular the MS2 case in general results in more endowments.
- The Per Capita Convergence approach can result into excess emission endowments. However, under the S550e profile and the CPI baseline, these excess emissions are not significant.

3.2.2. Robustness of results for the S550e profile

Figure 9 illustrates the robustness of the results for varying the key parameters in the endowment schemes, i.e. the participation thresholds for the emission reduction stage in MS1 and MS2, and the Transition Constant in MS3. More specifically, for MS1: the threshold varies between 80 and 120 % of world average per capita emissions; for MS2 the Capacity-Responsibility threshold varies between 10 and 15 and for MS3, the Transition Constant is between 50 and 100.

Figure 9: Robustness of results for the Multi-Stage cases under the S550e profile

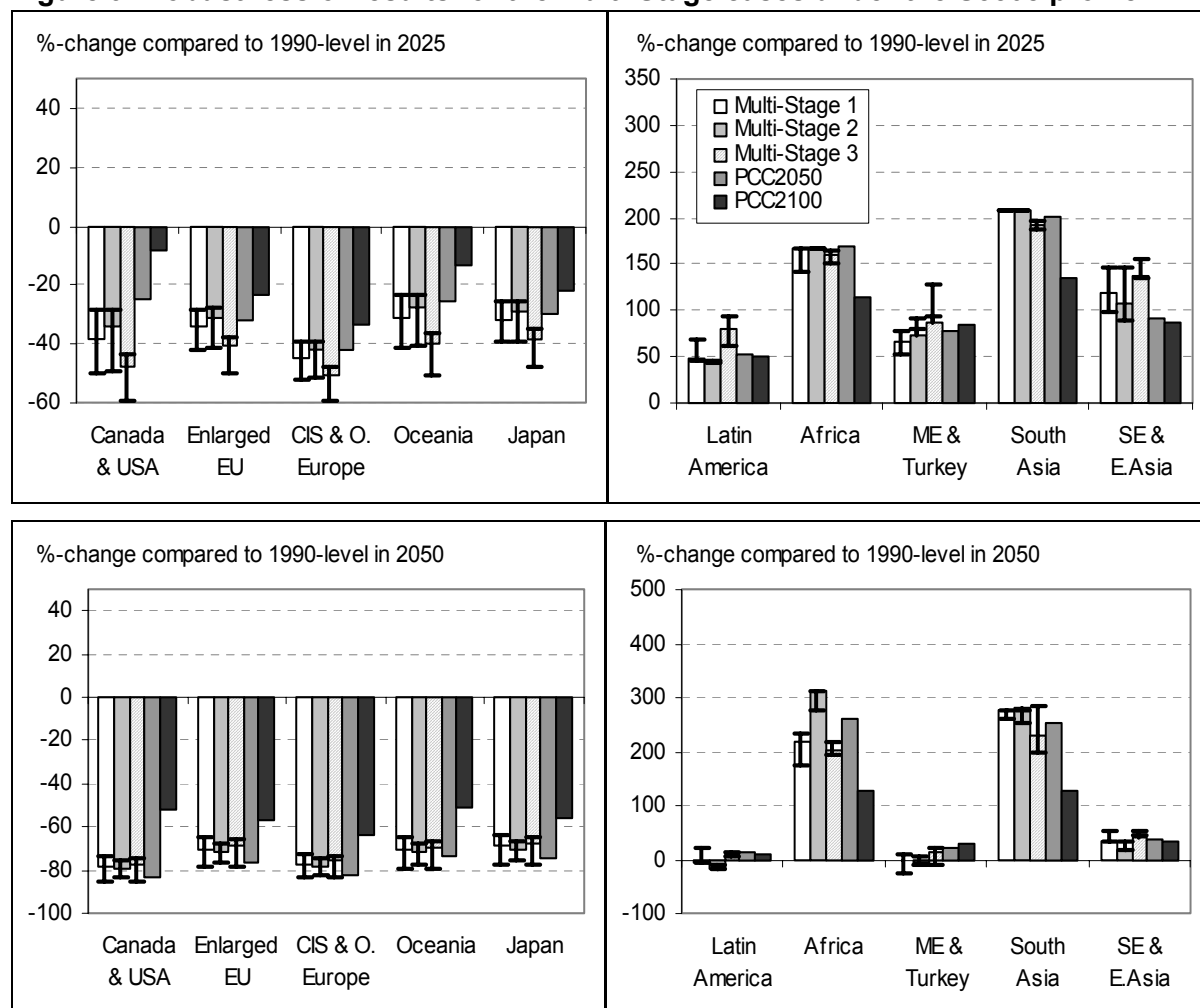

Source: FAIR 2.0 model (den Elzen, 2002; den Elzen and Lucas, 2003)

- For the middle- and high-income non-Annex I regions, the changes in the parameters do affect the outcomes, but MS3 still provides the largest endowments, while the MS1 and MS2 generally impose the lowest ones.
- For the low-income non-Annex I regions, changes of parameters for the MS1 and MS2 cases do not affect the outcomes in the short-term, as they do not yet participate in the emission reduction stage. For MS3, the effect of changing the transition constant is also small.
- For the Annex I regions, MS3 imposes the lowest endowments in the short-term, and the PCC2100 the largest ones. The PCC2050 case may no longer result into the larger endowments than the Multi-Stage cases, depending on the parameter settings of the Multi-Stage cases. In general, the differences between the outcomes of MS1 and MS2 are not significant.
- For the middle-income and high-income non-Annex I regions, different thresholds for the entry into stage 2 can have a significant influence on the endowments under the MS1 regime, since their per capita emissions are close to the world average (especially for the Middle East). Changing the Capacity-Responsibility threshold (MS2) seems to have a smaller impact on the outcomes.

- For the low-income non-Annex I regions, the relative endowments do not change significantly and MS2 still results in the largest endowments in the long-term.

3.3. Regional endowments under the S650e constraint

3.3.1. S650e, reductions from Reference case to 2025 and 2050

Table 12 provides a synthetic view at the dates at which non-Annex I regions start to participate in the de-carbonisation and burden-sharing stages.

Table 12: S650e, participation of non-Annex I regions in the de-carbonisation and burden-sharing stage for the Multi-Stage cases.

Regions	Central America	South America	North Africa	West Africa	East Africa	South Africa	Middle East	South Asia	East Asia	South-East Asia
Entry to Stage 2	2015	2012	2040	----	----	2040	2012	2050	2015	2025
Entry to Stage 3										
Multi-Stage 1	----	----	2090	----	----	2045	2012	----	2045	----
Multi-Stage 2	2055	2045	2075	----	----	----	2045	2080	2040	2050
Multi-Stage 3	2035	2030	2065	----	----	2060	2025	2075	2035	2050

Note: for each region, white-boxes indicate the earliest entry case, dark-grey the latest, and light-grey in between

Figure 10: Change in the CO₂e emission endowments relative to 1990 for the Multi-Stage and Per Capita Convergence cases in 2025 and 2050, S650e

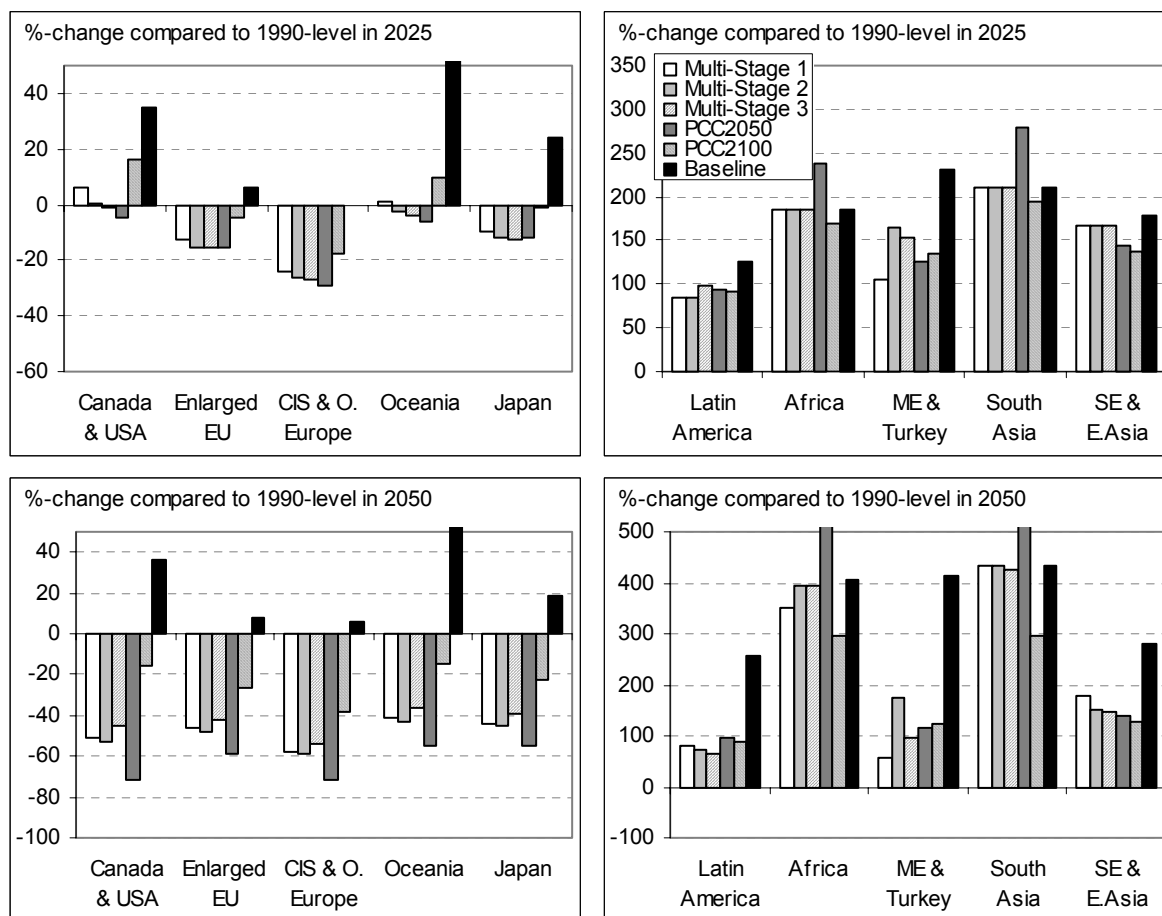

Source: FAIR 2.0 model

The key findings of the analysis of endowments for the S650e case can be summarised as follows:

Multi-Stage scenarios:

- For the emission limitation stage in all Multi-Stage cases all non-Annex I regions, except West- and East Africa, participate before 2050. However, compared to the S550e profile many regions participate much later.
- Compared to MS2, the MS3 case results into an earlier participation in the emission reduction stage of non-Annex I regions with relatively high per capita emissions (such as East Asia, or South- and Central America).
- For the Annex I regions, the MS1 case results in the largest endowments in both the short and long-term, due to the earlier participation in the burden sharing of some non-Annex I regions, as compared to the MS2 and MS3 cases.
- For some middle-income non-Annex I regions like South- and Central America, Middle East & Turkey, MS1 imposes the smallest endowments because these regions almost directly enter the emission reduction stage. Conversely, MS3 allows these regions to benefit of a longer transition period.
- Under the S650e profile, there is no need for the low-income non-Annex I regions to participate before 2050.

Per Capita Convergence scenarios

- Like under the S550e profile, the PCC2100 case results into much larger endowments for the Annex I regions than the Multi-Stage and PCC2050 cases. The PCC2100 case under the 650e profile results in the largest endowments for the Annex I regions and to the smallest ones for most non-Annex I regions (except Middle East & Turkey).
- The PCC2050 case results into smaller endowments for Annex I regions than the Multi-Stage cases, except for the Enlarged EU.
- For the more developed non-Annex I regions, MS3 no longer results into the largest endowments. PCC2050 now imposes the smallest endowments to the South-East & East Asia region. MS1 does so for the Middle-East & Turkey as the region reaches the world average threshold much earlier than the second Capacity-Responsibility threshold in MS2 and as, conversely to MS3, no gradual stabilisation is allowed.
- For the least developed non-Annex I regions (South Asia and Africa) the PCC2050 results by far in the largest endowments of emissions, including large amounts of excess emissions. At the same time there are no or hardly any differences in the outcomes for the Multi-Stage cases since these regions do not yet participate before 2050.

3.3.2. Robustness of results for the S650e profile

- In general, the results are rather robust, since changing the participation thresholds or transition constant has only a small impact on the endowments of the high-income non-Annex I regions (Middle East & Turkey, Latin America) and Annex I regions. In general, the pattern of relative efforts resulting from the cases remains unaffected.
- For the Annex I regions, the PCC2050 remains the approach that provides the smallest endowments, and the PCC2100 the largest ones. The Multi-Stage cases have an intermediate position. Among them, MS1 is no longer the one presenting systematically the largest endowments.

- For the middle-and high-income non-Annex I regions, there are less clear differences between the cases.
- In general, the emissions endowments under S550e profile are more sensitive to changes in the participation thresholds in the short-term than in the long-term. An opposite pattern is found for the S650e profile, due to the delayed entry-dates of the non-Annex I regions in the emission reduction stage.

Figure 11: Robustness of results for the Multi-Stage cases under the S650e profile

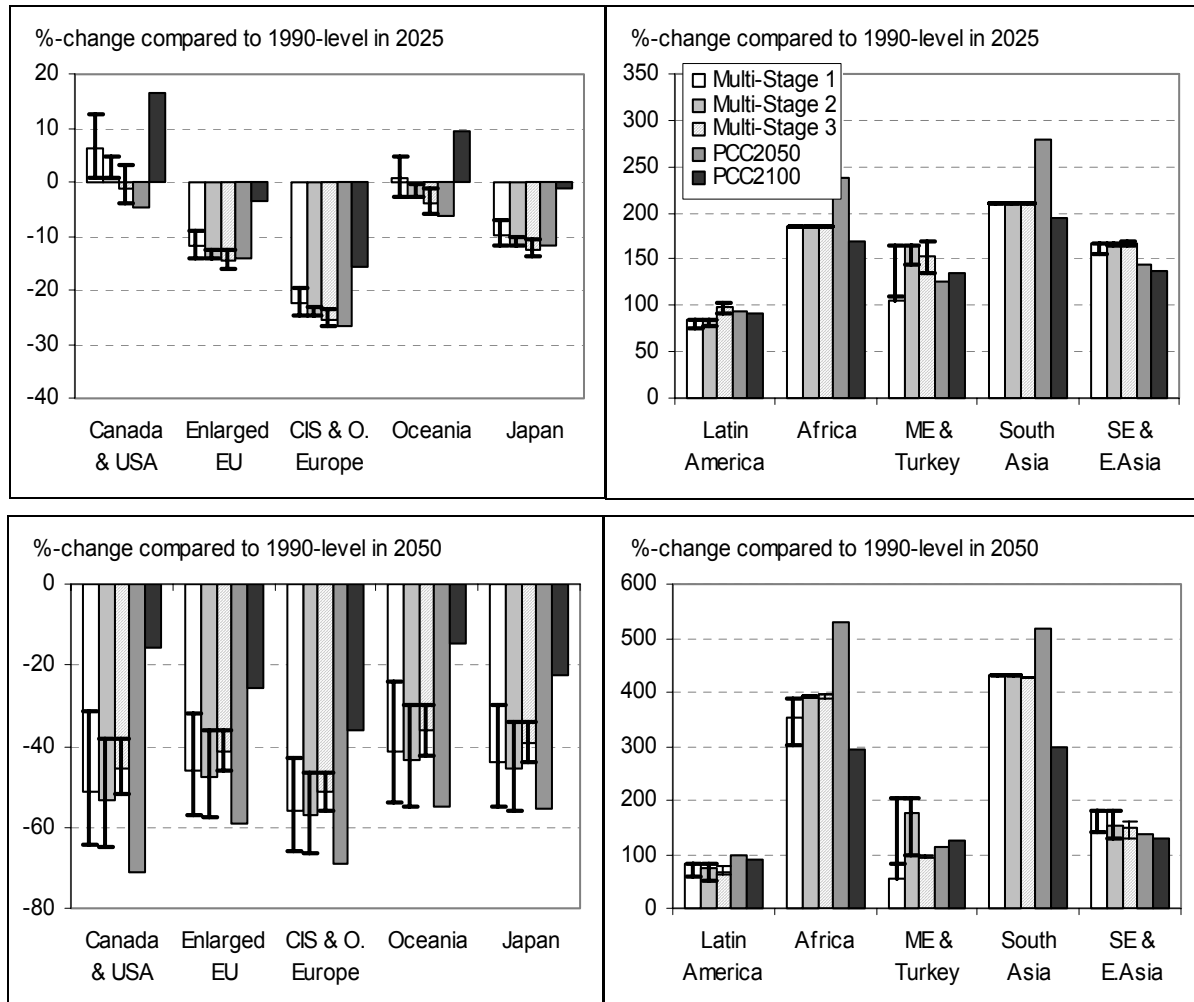

Source: FAIR 2.0 model (den Elzen, 2002; den Elzen and Lucas, 2003)

3.4. Conclusions

The comparative outcomes of the different commitment schemes are presented in Figure 12 for the S550e profile. The approach resulting into the largest emissions endowments are indicated in grey. The approaches resulting into the smallest emissions endowments are indicated in black. White indicates an intermediate position.

Figure 12: Regional relative scores for the Multi-Stage and Per Capita Convergence reference cases by 2025 (left-side boxes) and 2050 (right-side boxes), S550e

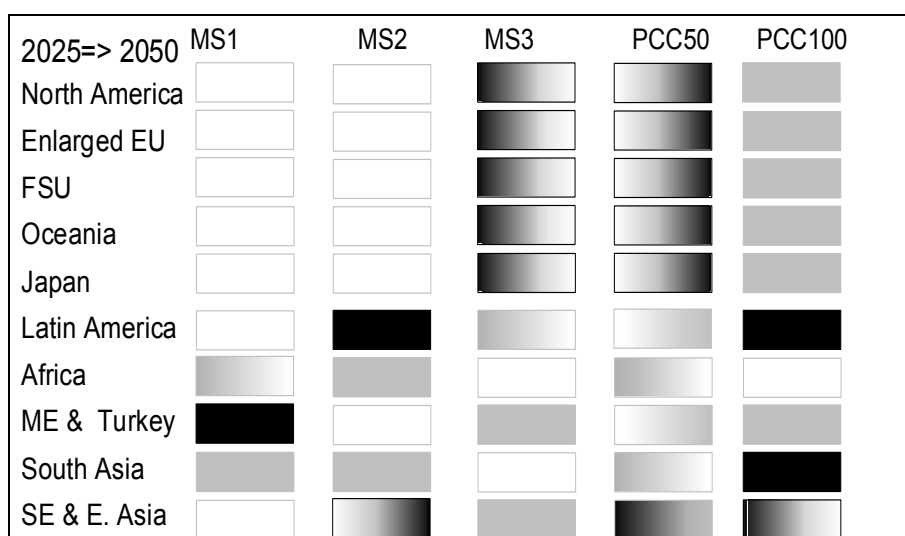

Note: grey box for the largest endowments, black for the smallest, white for the intermediate cases

Source: FAIR 2.0 model (den Elzen, 2002; den Elzen and Lucas, 2003)

Results of the Multi-Stage cases under the S550e profile

- For the middle- and high-income non-Annex I regions, the transition period under the MS1 and MS2 cases is generally shorter than under MS3. This results into larger endowments under the MS3 case than under MS1 and MS2.
- For the Annex I regions, the MS2 case results in the largest endowments in the short-term, whereas the MS3 case requires the smallest. This is the result of the earlier entry of middle- and high-income non-Annex I regions in MS2. In the long-term, all Multi-Stage cases lead to high emissions reductions.
- For the low-income non-Annex I regions, the MS3 case results into the smallest endowments due to the relatively low path in the transition stage, as compared to the MS1 and MS2 cases. Generally, the low-income regions are more sensitive to the choice of the Multi-Stage option.

Multi-Stage cases compared to Per Capita Convergence cases in the S550e profile

- For the Annex I regions the PCC2100 case results into very large endowments. In the short-term, the MS3 case results into the smallest endowments, while in the long-term this is the case for PCC2050. However, the differences between the Multi-Stage cases and PCC2050 are small.
- For the middle- and high-income non-Annex I regions (Latin America, Middle East & Turkey) the MS3 and PCC2050 cases results into the largest endowments; the MS1, MS2 and also the PCC2100 cases impose smaller ones.
- For the low-income non-Annex I regions (South Asia, Africa) the PCC2050 case generally provides larger endowments than the Multi-Stage cases, except in the very short-term (2010-2020) due to some excess of emissions endowments. The MS2 case produces large endowments for these regions because of the late entry in the emission reduction stage. On the contrary, the PCC2100 case results in the smallest endowments.

Results of the Multi-Stage cases under the S650e profile

- In general, the emissions reductions in the Multi-Stage cases in the short-term are limited to the Annex I regions and high-income non-Annex I regions (Central- and South America and Middle East & Turkey). However, these non-Annex I regions then enter only late in the emission reduction stage (stage 3), particularly in MS1.
- For the Annex I, the MS1 case results in the largest endowments in both the short and long-term, due to the earlier participation of some non-Annex I regions in stage 2, but the differences between the Multi-Stage cases are relatively small.
- For some middle-income non-Annex I regions, the MS3 case results into relatively large endowments in the short-term, because it allows for quite a long transition period.
- For the low-income non-Annex I region there are no or only very small differences in the outcomes for the Multi-Stage cases, since these regions do not yet participate before 2050

Multi-Stage cases compared to Per Capita Convergence cases in the S550e profile

- For the Annex I regions under the S550e profile, the PCC2100 case results in substantially larger endowments than all other cases.
- For the same regions, the PCC2050 case results into smaller endowments than the Multi-Stage cases in the long-term, but not in the short-term, when MS3 provides the smallest endowments (see Figure 12).
- For the middle- and high-income non-Annex I regions the MS3 approach no longer results in the largest endowments. The differences between the Multi-Stage cases are small. The Per Capita Convergence cases still impose small endowments to the South East & East Asia region. For the Middle-East & Turkey this the case in the MS1 approach, as the world average threshold is met much earlier than the second Capacity-Responsibility threshold in MS2 and no stabilisation period is allowed, as in the case of MS3.
- For the low-income non-Annex I regions (South Asia, Africa) the PCC2050 case by far results in the largest emission endowments due to significant amounts of excess emissions over the period 2000-2050, and conversely the PCC2100 in the smallest endowments.

The S550e versus the S650e profile

Figure 13 compares the outcomes of the different schemes in 2025 under the S550e profile with those under the S650e profile.

Figure 13: Regional relative scores for the Multi-Stage and Per Capita Convergence reference cases by 2025 for the S550e profile (left-side boxes) and S650e profile (right-side boxes)

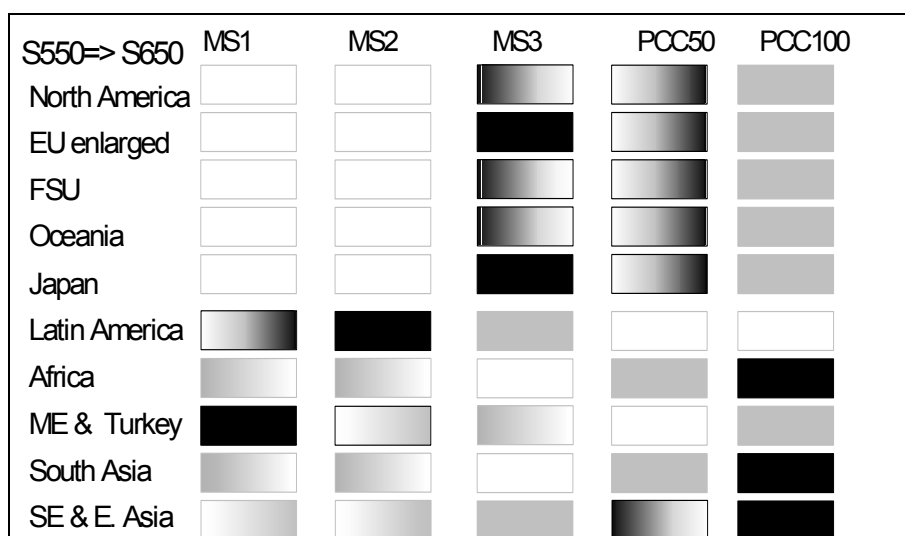

Note: grey box for the largest endowments, black for the smallest, white for the intermediate cases

Source: FAIR 2.0 model (den Elzen, 2002; den Elzen and Lucas, 2003)

- Changing from the S550e to the S650e profile significantly influences the relative endowments of individual world regions under the Multi-Stage and the PCC2050 cases. Only the endowments under the PCC2100 case for both the Annex I regions and non-Annex I regions remain unaffected in relative terms.
- For the low-income non-Annex I countries, the change from the S550e to the S650e profile has the largest influence on the relative endowments. Under the S650e profile the large amount of excess emissions (even in the long-term) results into the largest endowments for the PCC2050 case. The higher participation thresholds imply no differences as these regions still follow their baseline emission levels.

Robustness of the results

In general, the emissions reductions under S550e profile are more sensitive to changes in the participation thresholds for the emission reduction stage (stage 3) in the short-term and in the long-term. An opposite pattern is found for the S650e profile, due to the delayed entry-dates of the non-Annex I regions in the emission reduction stage.

4. Abatement costs and impacts on the energy systems and on the economies

Sectoral models of the energy sector and of other greenhouse gas emitting activities allow assessing the cost of adjusting the consumption profiles and technology-mix to a situation of constrained emissions. When emission trading is considered, as is the case in this study, the total cost for a given region combines the cost of domestic reductions with the purchase or sale of emission quotas. The ratio of this total cost to the GDP of each region provides a good indicator of the effort that is directly imposed by the endowment scheme. This 'effort rate' however does not account for the full adjustment of the many components of the economy, which can only be described in a general equilibrium perspective.

The first section of this chapter describes the economic impacts of the emission reduction pathways and endowment schemes, for the 2025 time-horizon and with a particular focus on the energy sector. It is based on the results of the POLES model. Section 2 provides a general equilibrium analysis of the overall economic impacts, from the use of the GEM-E3 model. Finally, the IMAGE-TIMER modelling system allows to put the medium-term analyses in a longer term perspective, while providing an image of the sectoral impacts of emission reduction pathways to 2050 and 2100.

4.1. Impacts on the energy sector from the POLES model

4.1.1. World carbon price

The POLES model allows computing, through a year-by-year iterative process, the carbon value that allows for compliance to the quantitative emissions targets of any set of participating countries or regions, under the hypothesis of emission trading. For the 2002-2010 period, the 'bubble' that is subject to the emission constraints is limited to the participating Annex I parties. The Kyoto targets are supposed to be met in 2010. Although they comply with their national intensity target, the USA is assumed not to participate in the emission trading regime.

Beyond the Kyoto Protocol horizon, the bubble encompasses all world regions. It is considered that the non-Annex I countries participate fully to the trading system, through 'full-access CDM' for those that are not subject to any constraint. Table 13 below displays the evolution of the carbon value for the two profiles considered: S550e and S650e. For a given constraint and given the fact that the bubble of participating countries remains the same in all scenarios, only one endogenous carbon value is produced for each profile.

- *The Kyoto Protocol horizon*

Up to 2010, both profiles are identical. The carbon value reaches 9 €/tCO₂e in 2010, date at which the Kyoto Protocol is assumed to be fully implemented by the Annex I Parties (except the US). The Kyoto Protocol is assumed to be reached without the use of CDM credits. The Former Soviet Union is assumed to bank 60% of its available emissions surplus, while the Eastern and Central Europe countries do not use any of their surplus.

Table 13: The international Carbon Value in 2010, 2015, 2020 and 2025 for both profiles S550e and S650e, POLES model.

(€/tCO ₂ e)	2010	2015	2020	2025
S550e	9.3	21.4	50.1	142.9
S650e	9.3	9.9	17.7	32.5

Source: POLES model

- *Beyond the Kyoto Protocol*

The carbon value obtained beyond the Kyoto Protocol reflects the degree of constraint imposed on the emitting activities. In both cases, the value falls immediately after Kyoto with the introduction of the non-Annex I countries in the bubble because of the less severe burden imposed on the global bubble and of the significant enlargement of the scope of the abatement options. However, the carbon value then increases rapidly: in 2015 it reaches 21.4 €/tCO₂e for the S550e and remains around 10 €/tCO₂e for the S650e. In the longer term, the increase is sharp in the S550e, to 50 €/tCO₂e and 143 €/tCO₂e, respectively in 2020 and 2025. The less constraining S650e profile results in more moderate values: 18 €/tCO₂e and 32.5 €/tCO₂e, respectively in 2020 and 2025.

4.1.2. The S550e profile

The following analysis for the thirteen regions allows drawing some conclusions about the different scenarios. In the case of the S550e profile, all regions have positive costs in most of the scenarios considered. Only South Asia and Africa show benefits in most scenarios.

The PCC2100 scenario displays striking results: it is by far the least constraining scenario for Annex I countries, and it entails relatively heavy sectoral costs for non-Annex I regions, up to almost 1% of GDP for Middle-East & Turkey over the 2011-2025 period. Even India and Africa bear positive costs in this scenario. Over the same period, the USA are in a position to export quotas in this scenario, although the domestic cost exceeds the gains from trading.

Figure 14. Cumulative reductions and discounted costs over 2011-2025 for large regions and key parties (S550e profile)

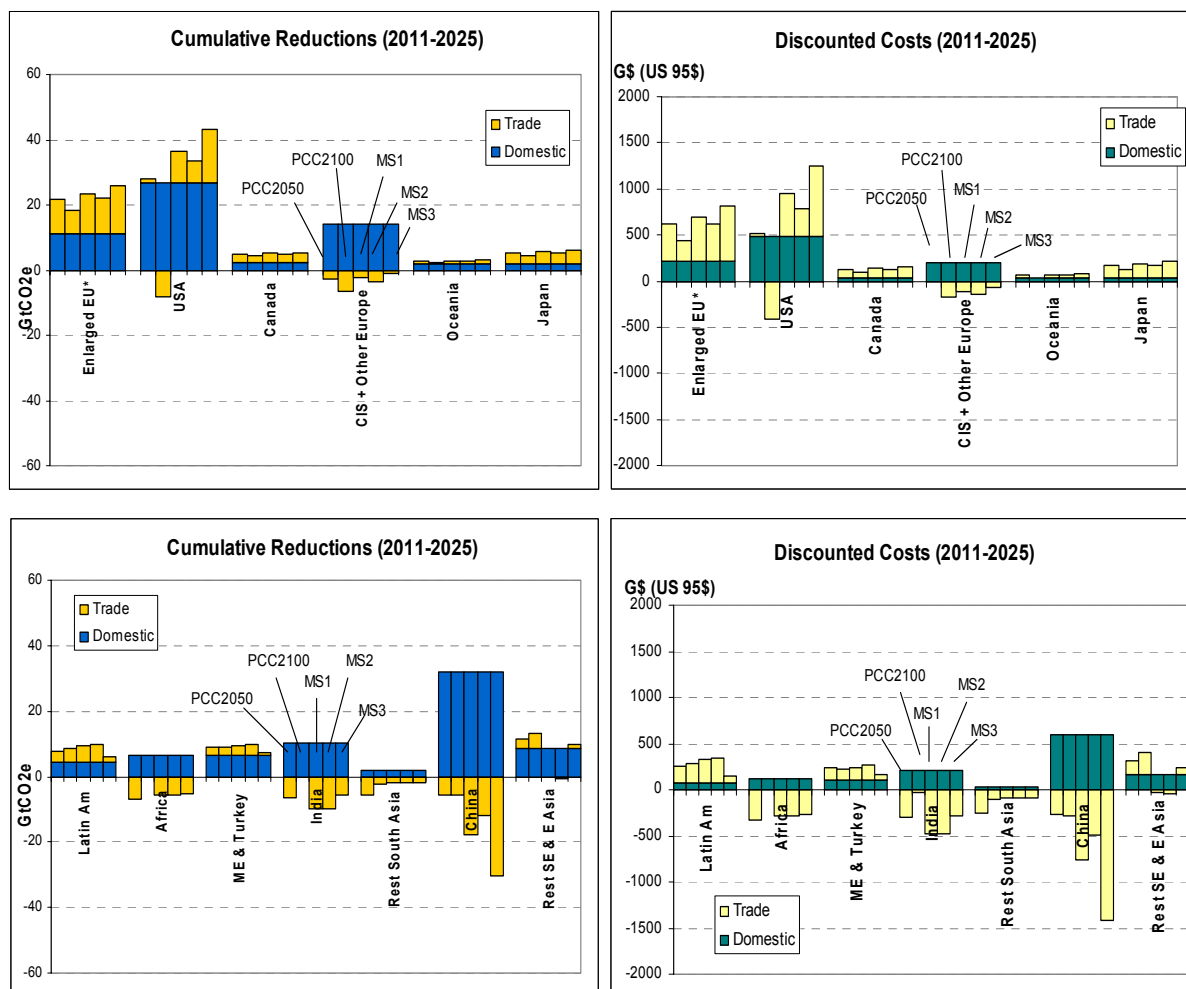

Note: left hand diagrams illustrate the cumulative reductions in each region, with domestic reductions and imports of quotas (if any) on the positive part of the Y-axis and with reductions for exports of quotas on the negative part of the Y-axis; in a similar way, right hand diagrams illustrate the corresponding costs (positive part of the Y-axis) or revenues (negative part of the Y-axis)

Source: POLES model

When the PCC2100 scenario is excluded, all the other scenarios show similar trends: Annex I regions, Latin America and Middle East & Turkey import quotas, while the exporting regions are South Asia, for the largest part, and Africa.

Figure 15 illustrates the effort rate, i.e. the ratio of total discounted cost (or net revenue) to the discounted GDP of each region. It shows in particular that the PCC2050 scenario entails homogenous effort rates among Annex I parties (about 0.50 %) over the full period, except for CIS and Canada, which in all cases have to face heavy costs. It has also to be noted that China has a positive effort rate over the period in the two Per Capita Convergence scenarios, while its quota exports will compensate for the cost of domestic reductions in the Multi-Stage scenarios, and even exceed this cost in the MS3 case.

Figure 15. Discounted effort rate (2011-2025) for large regions and key parties (S550e profile)

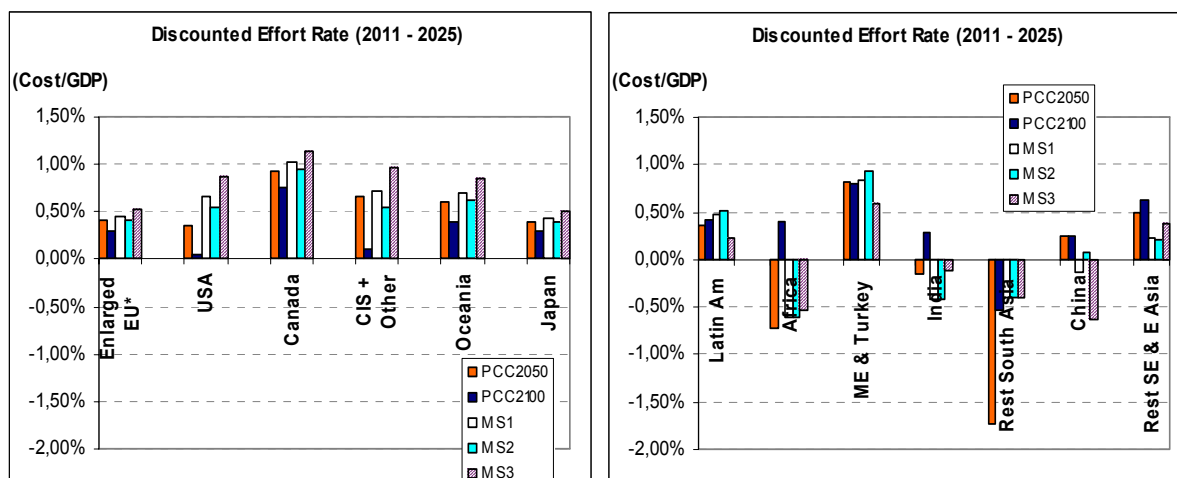

Source: POLES model

The volumes of endowments traded are more important in the three Multi-Stage scenarios than in the Per Capita Convergence scenarios in 2015: 1.80 GtCO₂e for both MS1 and MS2, 2.0 for MS3 vs. 1.45 and 1.3 GtCO₂e only for PCC2050 and PCC2100. In 2025 the differences are more pronounced: 4.3, 3.9 and 5.7 GtCO₂e for MS1, MS2 and MS3 respectively vs. 3.1 and 2.6 GtCO₂e for PCC2050 and PCC2100.

Figure 16. Volume of traded credits in 2015 and 2025 (S550e profile)

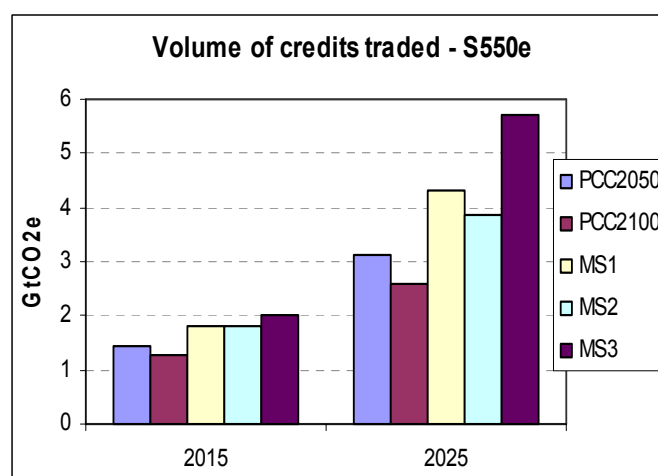

Source: POLES model

4.1.3. The S650e profile

The results show the same type of profiles as in S550e, although the orders of magnitude in terms of reductions, costs and purchases of quotas are smaller. The cumulated discounted effort rates also show the same trends.

However some differences are worth noticing. First, the net costs that Africa and India had to bear in the PCC2100-S550e scenario are now changed into a net gain as exports more than compensate for the domestic costs. Secondly, South East & East Asia now supplies credits in the MS3 scenario, instead of purchasing, as in the S550e profile. South East & East Asia

bears roughly no effort rates in the three Multi-Stage scenarios (domestic costs are compensated by sales).

Apart from this, the main conclusions drawn previously are roughly the same, especially with regards to the peculiarity of the PCC2100 scenario, which remains the least demanding for Annex I parties and consequently the least advantageous for non-Annex I parties.

Except in China and South East & East Asia, the PCC2050 leads to the greater benefits for non-Annex I regions than the three Multi-Stage scenarios. On the opposite, China and South East & East Asia bear nil or even negative effort rates in the Multi-Stage scenarios.

Figure 17. Cumulative reductions and discounted costs over 2011-2025 for large regions and key parties (S650e profile)

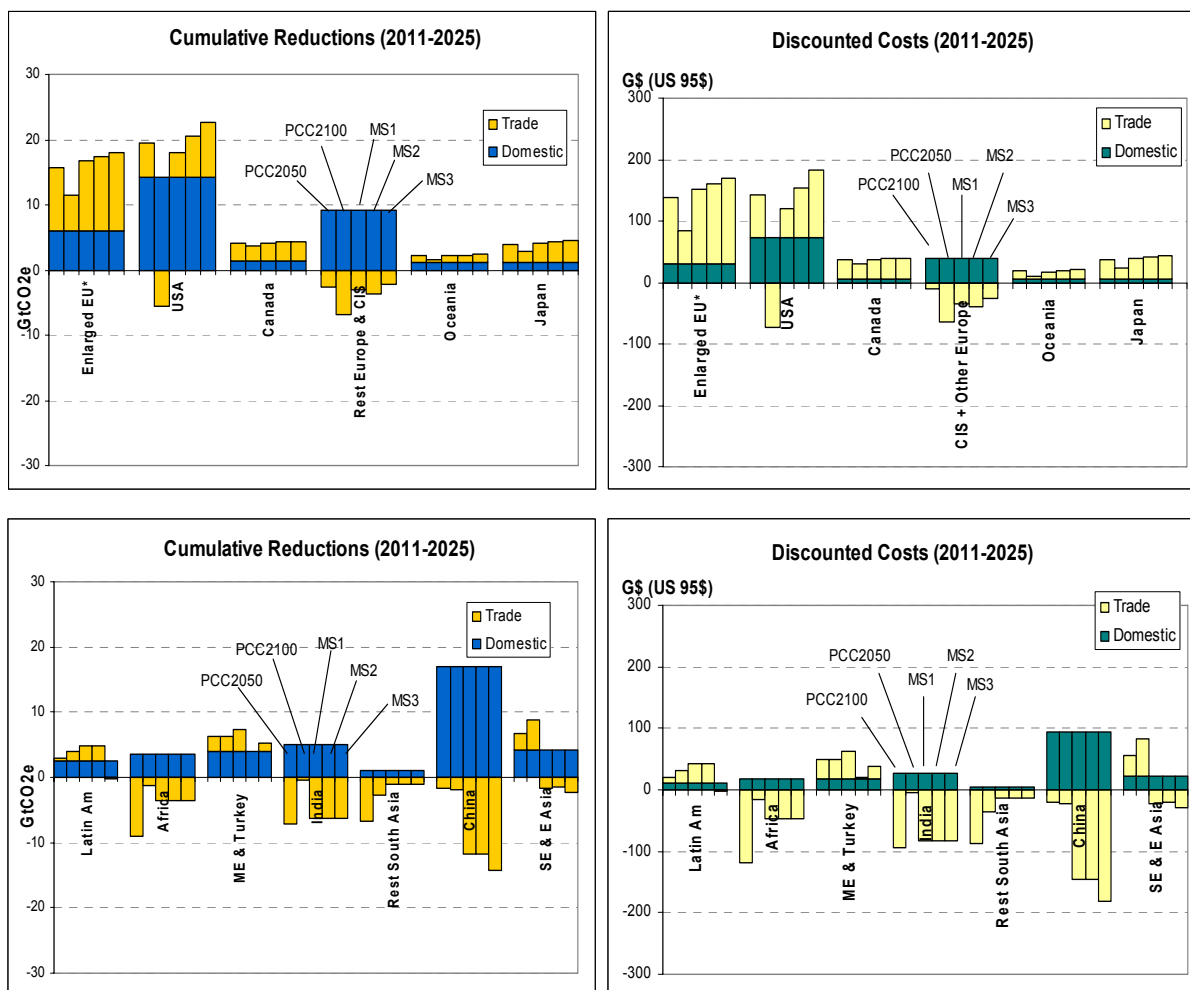

Source: POLES model

Figure 18. Discounted effort rate (2011-2025) for large regions and key parties (S650e profile)

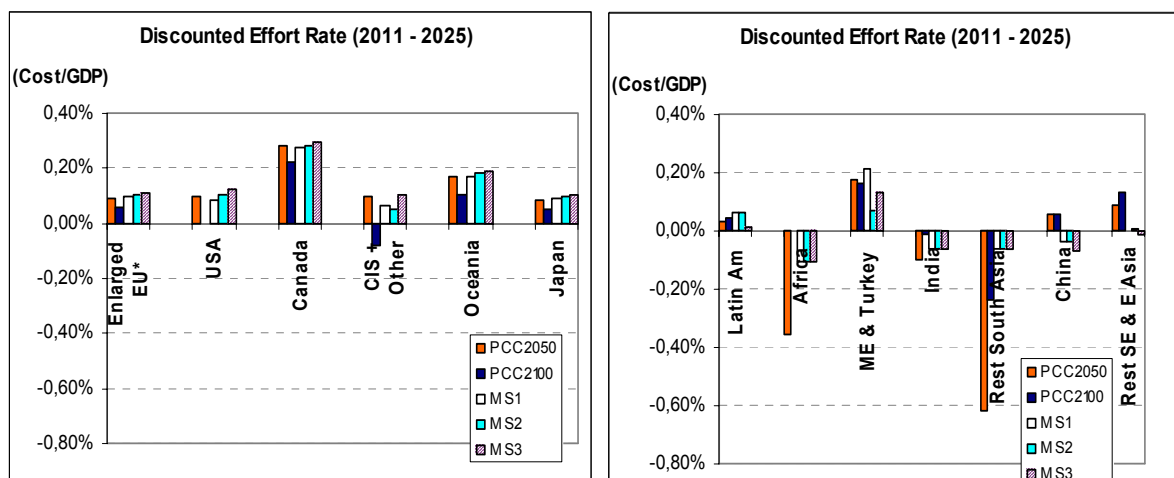

Source: POLES model

The volume of credits traded in 2015 is roughly the same in PCC2050 and the three Multi-Stage: 1.3, 1.4, 1.5 and 1.5 GtCO₂e respectively, vs. 1 GtCO₂e in the PCC2100. It is still true in 2025: the exchanges of credits amount to 3.1, 2.9, 2.9 and 3.1 GtCO₂e in respectively PCC2050, MS1, MS2 and MS3, vs. 1.6 GtCO₂e only in PCC2100.

Figure 19. Volume of traded credits in 2015 and 2025 (S650e profile)

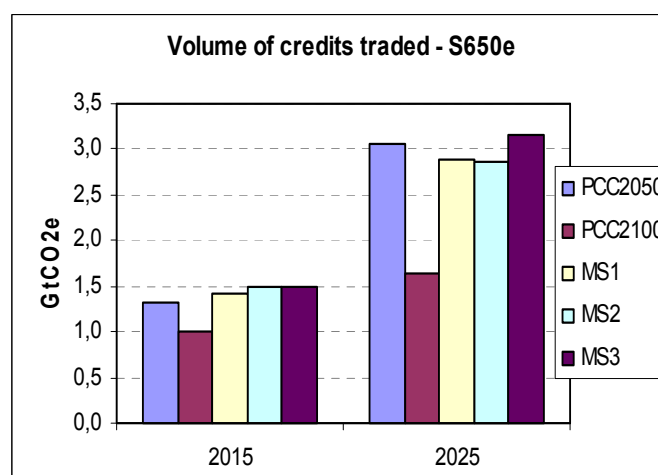

Source: POLES model

4.1.4. The pattern of international emission trading

Whereas, in a system with flexible mechanisms, the impacts on the world energy system are driven by the stringency of the global target (see section 4.1.6), the pattern of international emission trading and the associated financial flows crucially depends on the regional endowment scheme.

In all cases, most industrialised regions – Europe, Japan, Canada and Oceania - are net importers of emission quotas, as illustrated in Figure 20 and Figure 21. The USA, however, turn into a major quota exporting region in the Per Capita Convergence-2100 case, both for the S550e and S650e profiles. Africa, India and, to a lesser extent, the Rest of South Asia are in all cases major emission quotas exporting regions, except in Per Capita Convergence-2100, where their role as exporters is almost negligible.

This confirms the peculiarity of the Per Capita Convergence-2100 case, while more similarities are to be found in Per Capita Convergence-2050 and the three Multi-Stage cases. To some extent, China is an exception to this general statement as its role as a potential exporter ranges from a very limited one in both Per Capita Convergence-2050 and Per Capita Convergence-2100 for S650e, to a large one in Multi-Stage 3 and S550e.

Figure 20: Trading structure for emission quotas and associated financial flows, S550e

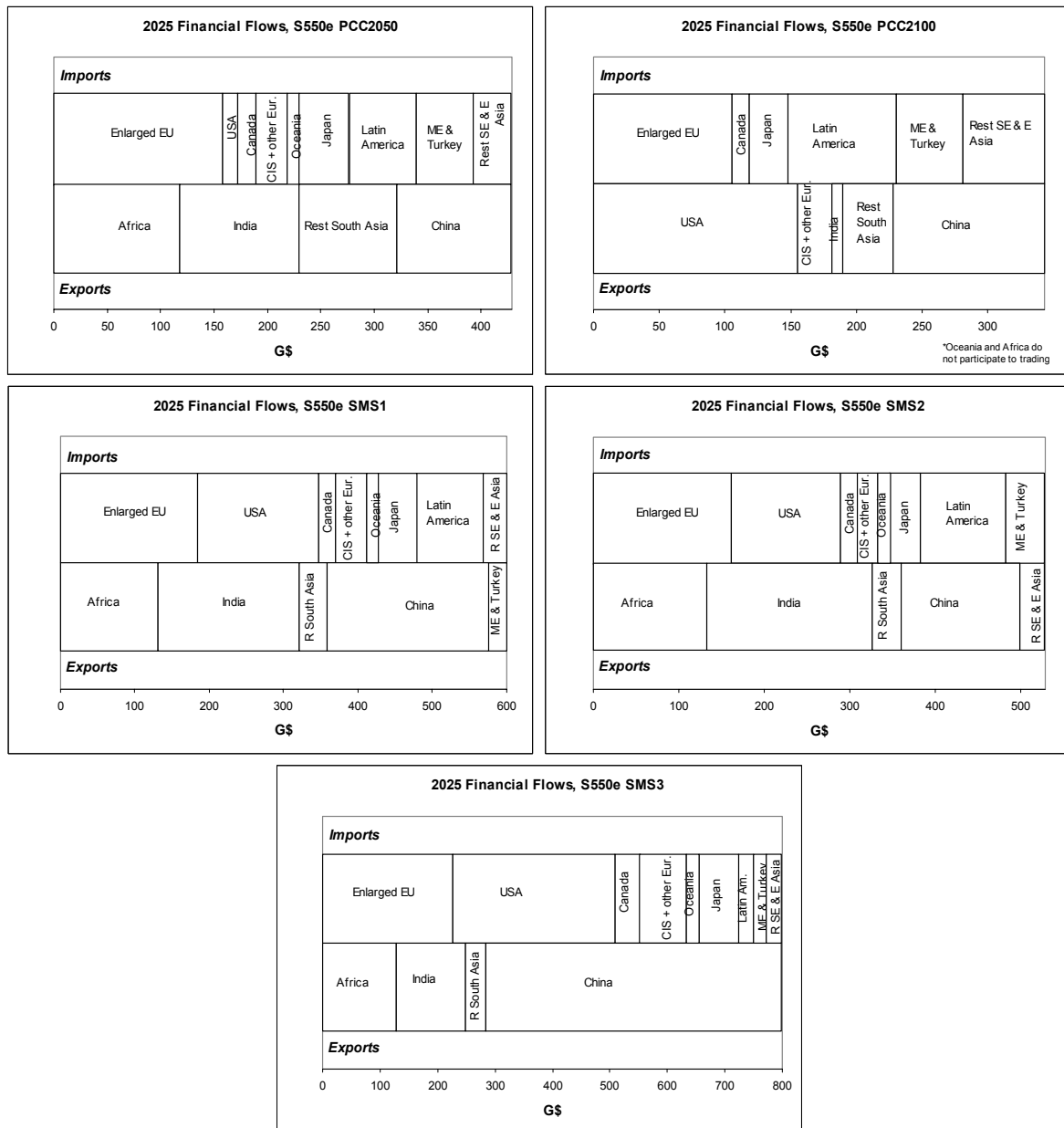

Source : POLES model

Figure 21: Trading structure for emission quotas and associated financial flows, S650e

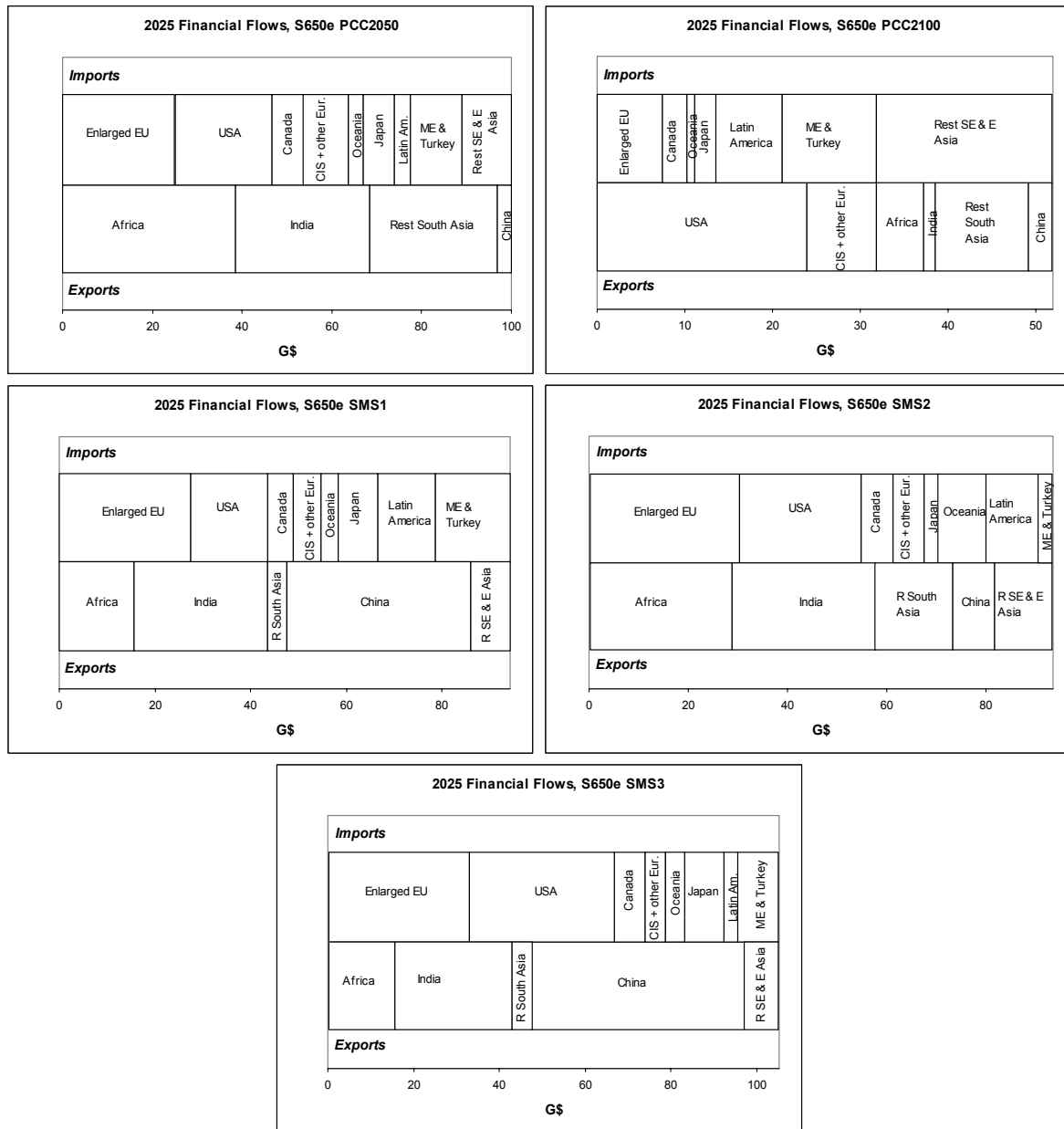

Source : POLES model

Table 14 provides details on the volume of financial flows associated with the trading of emission quotas and shows that these flows are four to eight times higher in S550e than in S650e. It also indicates that the Per Capita Convergence-2100 scheme – because it is the least stringent for industrialised countries – is the one that involves the least financial flows in both emission profiles, while Multi-Stage 3 involves the most.

Table 14: Direction of net trade in emission quotas and associated financial flows, S550e and S650e

Financial Flows (2025) billion €	S550e						S650e				
	PCC2050	PCC2100	MS1	MS2	MS3		PCC2050	PCC2100	MS1	MS2	MS3
Enlarged EU*	159	105	181	162	231		25	7	27	30	33
USA	5	-162	160	116	275		22	-23	16	25	35
Canada	20	12	26	23	33		6	4	6	7	7
CIS + Other Europe	33	-30	43	25	90		10	-8	6	6	6
Oceania	6	-1	10	8	17		3	1	3	4	4
Japan	42	27	48	43	64		8	4	9	9	10
Latin America	64	75	84	92	18		4	7	12	12	1
Africa	-123	1	-132	-132	-124		-39	-5	-15	-15	-15
ME & Turkey	47	45	48	60	41		11	10	15	2	8
India	-111	-8	-198	-198	-123		-30	-1	-28	-28	-27
Rest South Asia	-95	-35	-36	-36	-35		-28	-11	-4	-4	-4
China	-100	-107	-216	-140	-518		-3	-4	-38	-38	-49
Rest SE & E Asia	53	78	-19	-22	29		11	19	-9	-8	-10
Total financial flow	429	343	600	529	800		100	52	94	94	105

Source: POLES model

4.1.5. Synthesis on effort rates in S550e and S650e for 13 regions

Table 15 and Table 16 provide a synthesis of the results on the 13 regions effort rates for the 2025 horizon. As underlined above, effort rates in 2025 are obviously much lower in the S650e case than in S550e. As an illustration, the 2025 effort rates range between -1.56% (Rest South Asia, PCC2050) and +0.62% (Canada, MS3) in S650e, against -4.68% (Rest South Asia, PCC2050) and + 4.69% (CIS + other Europe, MS3) in S550e.

Table 15. Effort rate in 2025 (S550e profile)

2025 effort rates	PCC2050	PCC2100	MS1	MS2	MS3
Enlarged EU*	1,28%	0,89%	1,44%	1,30%	1,81%
USA	1,22%	0,18%	2,28%	1,99%	3,04%
Canada	2,47%	1,88%	2,82%	2,63%	3,35%
CIS + Other Europe	3,12%	1,41%	3,40%	2,90%	4,69%
Oceania	1,72%	1,10%	2,07%	1,86%	2,65%
Japan	1,31%	0,99%	1,43%	1,31%	1,78%
Latin America	1,37%	1,54%	1,60%	1,73%	0,72%
Africa	-2,00%	1,58%	-2,31%	-2,31%	-2,12%
ME & Turkey	2,61%	2,58%	2,60%	2,99%	2,38%
India	-0,31%	0,89%	-1,34%	-1,34%	-0,49%
Rest South Asia	-4,68%	-1,23%	-1,36%	-1,36%	-1,36%
China	0,83%	0,80%	0,11%	0,57%	-1,79%
Rest SE & E Asia	1,61%	1,99%	0,66%	0,61%	1,27%

Source: POLES model

Table 16. Effort rate in 2025 (S650e profile)

2025 effort rates	PCC2050	PCC2100	MS1	MS2	MS3
Enlarged EU*	0,22%	0,11%	0,23%	0,25%	0,27%
USA	0,30%	0,00%	0,26%	0,32%	0,38%
Canada	0,58%	0,41%	0,56%	0,59%	0,62%
CIS + Other Europe	0,56%	0,07%	0,45%	0,44%	0,57%
Oceania	0,41%	0,23%	0,40%	0,43%	0,46%
Japan	0,21%	0,11%	0,22%	0,23%	0,25%
Latin America	0,09%	0,14%	0,20%	0,20%	0,06%
Africa	-1,01%	0,02%	-0,30%	-0,30%	-0,30%
ME & Turkey	0,46%	0,45%	0,58%	0,21%	0,38%
India	-0,25%	0,10%	-0,22%	-0,22%	-0,22%
Rest South Asia	-1,56%	-0,57%	-0,16%	-0,16%	-0,16%
China	0,17%	0,16%	-0,05%	-0,05%	-0,13%
Rest SE & E Asia	0,25%	0,36%	0,00%	0,00%	-0,02%

Source: POLES model

The general results are that Annex I countries have positive effort rates, while the results concerning non-Annex I countries are more heterogeneous. Latin America and Middle East & Turkey have global positive costs in 2025, Africa and South Asia (especially Rest South Asia) generally gain from the setting of a general constraint on emissions and the use of trading for meeting objectives. Finally China and Rest South East and East Asia display a clear preference for MS-type schemes rather than the Per Capita Convergence-type in which it bears positive costs. In the S550e, all scenarios entail positive costs for the South East Asia regions, except MS3 for China.

As for the S550e profile, the 2100 Per Capita Convergence scenario presents particularly marked features, while the four others (2050 Per Capita Convergence, MS1, 2 and 3) appear more homogenous in terms of regional cumulative reductions, costs and effort rates, with nevertheless some regional differences.

The PCC2100 case is by far the least constraining scenario for Annex I parties and the most demanding for Non-Annex I parties. In this scenario, apart from Rest South Asia in both profiles, all non-Annex B regions bear positive costs, which can be much higher than those of Annex I regions. The case of Africa incurring a heavy effort rate in the S550e profile is particularly revealing of the likely difficult acceptability of such a scheme for developing countries. Middle East & Turkey and Rest South East and East Asia also have to bear large costs (these two regions show the highest effort rates in the S550e profile and have among the highest in the S650e profile).

The PCC2050 and the three Multi-Stage scenarios are all advantageous for low income regions such as Africa, India and Rest South Asia. The South East and East Asia bears positive costs for Per Capita Convergence scenarios and gains the most from endowments selling in the MS3 scenario. It must be noted that in the S550e case, South East & East Asia makes benefits from trading only in the MS3 scenario.

In the S650e case, PCC2050, MS1, MS2 and MS3 display very homogenous results for Annex I parties. The Multi-Stage scenarios appear generally more constraining for these parties than the Per Capita Convergence scenarios in the S550e case.

4.1.6. Impacts on the World Energy Balances

The Table 17 below provides a synthetic description of the POLES energy projection of the Common POLES-IMAGE reference case.

Table 17. CPI Reference – World Energy Balance

POLES - REFERENCE WORLD	2000	2010	2020	2030	y.a.g.r 2000-2030
Population (M)	6102	6855	7558	8164	1.0%
Per capita GDP (95\$/cap)	6786	8513	10506	12590	2.1%
GDP (G\$95PPP)	41407	58350	79400	102788	3.1%
Energy Intensity of GDP (toe/M\$95)	239	207	184	167	-1.2%
Primary energy (Mtoe)	9902	12088	14619	17204	1.9%
Carb intensity of energy (tCO2/toe)	2.38	2.43	2.53	2.60	0.3%
CO2 emissions (MtCO2)	23574	29407	36983	44799	2.2%
All GHGs emissions (MtCO2e)	32771	40132	49758	59349	1.9%
Primary Energy Supply (Mtoe)					
Solids	2348	2922	3743	4788	2.4%
Oil	3517	4224	5086	5862	1.7%
Gas	2148	2935	3794	4450	2.5%
Others	1889	2007	1997	2103	0.4%
of which					
Nuclear	660	804	789	870	0.9%
Large Hydro + Geoth	236	287	338	389	1.7%
New Renewables	171	235	301	367	2.5%
World Oil Price (\$95/bl)	26.5	23.7	28.7	34.9	0.9%

Source: POLES model

The S550e profile and the corresponding carbon value impose major changes in the world energy balance to the 2020-2030 horizon. The rate of overall energy efficiency improvement is strongly stimulated in the S550e case, as it more than doubles as compared with the Reference, rising from 1.2%/yr to 2.5%/yr. Through both demand limitations and inter-fuel substitutions, the consumption of solid fossil fuels is dramatically reduced: -80% compared to the Reference in 2030. The gas and oil consumption is also significantly affected (more than -30% in 2030). The decline in fossil-fuel use of course benefits other fuels: nuclear increases by 160% compared to the baseline, the new renewable by 130% and the large hydro by 8% in 2030. These increases correspond to average growth rates for the nuclear and the new renewable of 4.1% and 5.5% respectively. The decline in oil consumption brings about a significant decrease in the world oil price to 24.5\$/bl in 2030 and S550e compared to 34.9\$/bl in the baseline. It has to be noted here that the carbon capture and sequestration options are not considered in this medium term analysis.

Table 18. The S550e profile – World Energy Balance

POLES - 550ppmv profile WORLD	2000	2010	2020	2030	y.a.g.r 2000-2030
Population (M)	6102	6855	7558	8164	1.0%
Per capita GDP (95\$/cap)	6786	8513	10506	12590	2.1%
GDP (G\$95PPP)	41407	58350	79400	102788	3.1%
Energy Intensity of GDP (toe/M\$95)	239	206	160	113	-2.5%
Primary energy (Mtoe)	9902	11996	12730	11621	0.5%
Carb intensity of energy (tCO2/toe)	2.38	2.42	2.27	1.78	-1.0%
CO2 emissions (MtCO2)	23574	29064	28934	20669	-0.5%
Other GHGs emissions (MtCO2e)	9197	9302	10320	11195	0.7%
Primary Energy Supply (Mtoe)					
Solids	2348	2835	2175	867	-3.3%
Oil	3517	4248	4545	3907	0.4%
Gas	2148	2889	3555	2856	1.0%
Others	1889	2024	2456	3992	2.5%
of which					
Nuclear	660	800	1036	2249	4.2%
Large Hydro + Geoth	236	291	353	421	1.9%
New Renewables	171	252	498	845	5.5%
World Oil Price (\$95/bl)	26.5	23.7	25.5	24.5	-0.3%

Source: POLES model

Table 19. The S550e profile compared to the Reference

550ppmv profile / Reference	2000	2010	2020	2030
Energy Intensity of GDP (toe/M\$95)	0%	-0.8%	-12.9%	-32.4%
Primary energy (Mtoe)	0%	-0.8%	-12.9%	-32.4%
Carb intensity of energy (tCO2/toe)	0%	-0.4%	-10.2%	-31.7%
CO2 emissions (MtCO2)	0%	-1.2%	-21.8%	-53.9%
Other GHGs emissions (MtCO2e)	0%	-13.3%	-19.2%	-23.1%
Primary Energy Supply (Mtoe)				
Solids	0%	-3.0%	-41.9%	-81.9%
Oil	0%	0.6%	-10.6%	-33.4%
Gas	0%	-1.5%	-6.3%	-35.8%
Others	0%	0.8%	23.0%	89.8%
of which				
Nuclear	0%	-0.6%	31.3%	158.4%
Large Hydro + Geoth	0%	1.3%	4.3%	8.2%
New Renewables	0%	7.3%	65.7%	130.0%
World Oil Price (\$95/bl)	0%	-0.1%	-11.2%	-29.9%

Source: POLES model

In the S650e profile, which is less demanding than the S550e, the increase in overall energy efficiency improvement is less pronounced than in S550e: it is of slightly less than 50%, with efficiency improvement rising from 1.2%/yr in the Reference to 1.7%/yr. But the solid fuels are still heavily affected. Their use is almost halved in 2030 compared to the Reference (-46%). The oil consumption decreases by 11% while the impact on natural gas remains limited (-7% in 2030). The use of nuclear energy and of New Renewables increase by respectively 59% and 78%. The oil price reaches 31.8\$/bl in 2030 (-9% compared to the Reference).

Table 20. The S650e profile – World Energy Balance

POLES - 650ppmv profile WORLD	2000	2010	2020	2030	y.a.g.r 2000-2030
Population (M)	6102	6855	7558	8164	1.0%
Per capita GDP (95\$/cap)	6786	8513	10506	12590	2.1%
GDP (G\$95PPP)	41407	58350	79400	102788	3.1%
Energy Intensity of GDP (toe/M\$95)	239	206	172	145	-1.7%
Primary energy (Mtoe)	9902	11996	13648	14869	1.4%
Carb intensity of energy (tCO2/toe)	2.38	2.42	2.42	2.27	-0.2%
CO2 emissions (MtCO2)	23574	29064	33003	33806	1.2%
Other GHGs emissions (MtCO2e)	9197	9302	10694	11765	0.8%
Primary Energy Supply (Mtoe)					
Solids	2348	2835	2926	2582	0.3%
Oil	3517	4248	4866	5241	1.3%
Gas	2148	2889	3683	4128	2.2%
Others	1889	2024	2172	2919	1.5%
of which					
Nuclear	660	800	850	1383	2.5%
Large Hydro + Geoth	236	291	347	406	1.8%
New Renewables	171	252	407	654	4.6%
World Oil Price (\$95/bl)	26.5	23.7	27.5	31.8	0.6%

Source: POLES model

Table 21. The S650e profile compared to the Reference

650ppmv profile / Reference	2000	2010	2020	2030
Energy Intensity of GDP (toe/M\$95)	0%	-0.8%	-6.6%	-13.6%
Primary energy (Mtoe)	0%	-0.8%	-6.6%	-13.6%
Carb intensity of energy (tCO2/toe)	0%	-0.4%	-4.4%	-12.7%
CO2 emissions (MtCO2)	0%	-1.2%	-10.8%	-24.5%
Other GHGs emissions (MtCO2e)	0%	-13.3%	-16.3%	-19.1%
Primary Energy Supply (Mtoe)				
Solids	0%	-3.0%	-21.8%	-46.1%
Oil	0%	0.6%	-4.3%	-10.6%
Gas	0%	-1.5%	-2.9%	-7.2%
Others	0%	0.8%	8.8%	38.8%
of which				
Nuclear	0%	-0.6%	7.8%	58.9%
Large Hydro + Geoth	0%	1.3%	2.5%	4.2%
New Renewables	0%	7.3%	35.2%	78.1%
World Oil Price (\$95/bl)	0%	-0.1%	-4.3%	-8.9%

Source: POLES model

4.2. Economic assessment of endowment schemes with the GEM-E3 model

4.2.1. Introduction.

Previous chapters have dealt with the equity principles on which the scenarios were built and their implications for the environment and the world energy system. This chapter focuses on

the broader economic implications that the different generic architectures entail for each participating country and presents a model based quotas endowment scheme arising from restrictions on welfare impacts. The analysis draws from the results of the computable general equilibrium model GEM-E3-World and emphasis is given on issues of activity and welfare.

The emission quotas endowment scenarios, as defined in previous sections, were simulated through the introduction of an emission quotas market in conjunction with the environmental module of the model (where the price and the amount of quotas sold is determined endogenously). In modelling terms, an emission reduction constraint (relating to all greenhouse gas) was imposed for each climate change policy scenario, letting the model itself suggest how the agents internalize such a constraint into their choices.

4.2.2. Methodology and design of model applications.

Since deviations from the reference case are the key for policy evaluation in general equilibrium models, the study started with a refinement of the Reference scenario already developed within the GECS project. Specific attention was paid to ensuring that at least in terms of GDP and greenhouse gas emissions, the reference is consistent with the Common POLES-IMAGE scenario.

In the present study it is assumed that, within a region, the rights are distributed according to a grandfathering principle, corresponding to the level the agents were emitting in the base year. As regards to the revenues/losses realized through the sales/purchases of pollution quotas these are recycled in the economy by distributing them to the capital income for firms and to disposable income for households through direct transfers.

It is further assumed that a perfect (i.e. with no transaction costs) market for emission quotas is established for energy and non energy-related emissions. Moreover full trade of emission quotas is assumed among participating countries and sectors in order to obtain the least possible compliance costs leading to equal marginal abatement costs across all trading partners.

In order to avoid cases where countries with external balance problems are induced by the policy scenario to further deteriorate their current accounts it was assumed that the current account of the less developed countries would be fixed to the same level as in the reference case. As regards to capital mobility, capital was assumed to be fully mobile across sectors but not between countries. At a national level, this resulted in a uniform rate of return on capital for the whole economy.

In order to assess the economic costs or benefits of a particular quotas endowment scenario for a particular country/region a measure of economic welfare is a much more suitable indicator than GDP which essentially measures activity in the economy. The welfare index used in GEM-E3 is linked to the utility function of the representative household. It incorporates household consumption, leisure and the value of savings in terms of future discounted consumption. This function is assumed to be maximized by households in the face of an income constraint given the relative prices of goods and services.

4.2.3. Results.

- *The Carbon Value in the 550ppmv and 650ppmv profiles*

The emission reduction constraint generates a shadow value (carbon value), which increases the costs of greenhouse gas emitting activities. Then the internalization of this additional cost in the cost structures and choices of the economic agents is governed by their “optimizing behavior” (i.e. firms maximize profit, households maximize utility etc.). The

resulting equilibrium prices and quantities, incorporating both the primary and secondary effects of the policy intervention, leads to an endogenous least cost allocation of the abatement effort.

All 650-ppmv-profile scenarios have generated a broadly similar evolution of the carbon value. In 2025 carbon values reach their peak and are substantially the same in all endowment schemes (11 €99 t/CO₂ eq). This is not the case for the 550-ppmv-profiles where in 2025 carbon values are considerably different, ranging from 50.7 €99 t/CO₂e (PCC2100 scenario) to 59.7 €99 t/CO₂e (MS3 scenario). The explanation of this outcome is not straightforward, given that all scenarios produced identical emission reduction profiles (by assumption). Text-box 2 provides a description of the key underlying mechanisms.

Text-box 2: International endowments, redistributive effects, welfare changes and carbon value

The different carbon values imply in fact different adjustment costs, reflecting ultimately the repercussions of different initial quotas endowments to overall activity levels. Thus the question is how the different endowment schemes can induce different abatement costs at a given level of emission reduction. In a computable general equilibrium model with endogenous bilateral trade of goods and services the different endowments of quotas entails eventually different levels of overall activity, since the utilization of the proceeds of the quota sales differs among regions. This induces variations in the marginal abatement cost curve. In fact quotas endowments such as those implied by the Multi-Stage scenarios would produce the equivalent of a leftward shift of the implicit marginal abatement cost curve (MAC1 in Figure 22).

Figure 22: Implicit Marginal abatement costs

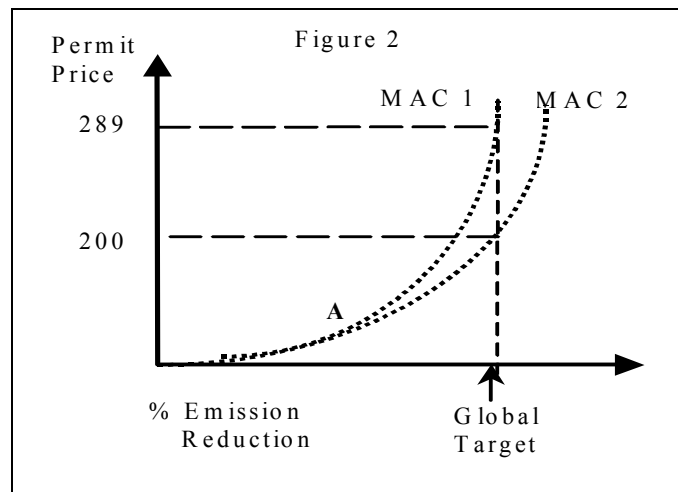

In other words, the smaller redistributive impacts of the PCC2100 scenario implies changes in demand of goods, services, intermediate inputs and primary factors of production (labor and capital), which altogether end at a lower level. This allows a relatively “easier” adjustment to the emission constraint as compared to the other scenarios (MAC2 in Figure 22). In cases where the target is relatively modest (point A) the differences in the regional and sectoral activity would tend to cancel out at the world level, leading to virtually identical carbon values. Thus the more stringent reductions a scenario imply the more crucial is the role of the initial quotas endowment.

- *Macroeconomic Implications*

Changes in World GDP.

Within the model three mechanisms to reduce greenhouse emissions operate, i/ reduction of production/consumption ii/ substitution between fuels and iii/ installation of abatement technologies. Installation of abatement technologies is considered as an intermediate input for the firm and not as an investment. Thus installing abatement technologies does not have any direct positive effect on GDP as it would have if modelled as investment

Any emission reduction policy would entail net costs for the economy reflected in GDP reductions. This activity reduction observed in all scenarios provides a useful summary indication of the overall abatement effort being as they are a distillation of a multitude of adjustments taking place in the world economy.

Table 22: %Change from Reference in World GDP and Production (2025).

	550 ppmv					650 ppmv				
	MS1	MS2	MS3	PCC2050	PCC2100	MS1	MS2	MS3	PCC2050	PCC2100
GDP	-2.29	-2.41	-1.94	-2.79	-2.68	-0.70	-0.67	-0.68	-0.87	-0.81
Agriculture.	-1.14	-1.91	0.37	-3.46	-5.01	-0.65	-0.55	-0.49	-0.99	-1.45
Coal.	-48.31	-48.49	-47.36	-48.29	-47.79	-25.85	-25.90	-25.99	-25.91	-25.76
Petroleum Refineries.	-23.40	-23.25	-23.84	-22.82	-22.30	-7.35	-7.34	-7.41	-7.41	-7.31
Distribution of Gas	-3.84	-3.84	-3.83	-3.72	-3.46	-0.87	-0.85	-0.87	-0.92	-0.86
Electricity.	-16.63	-16.57	-16.77	-16.36	-15.97	-5.53	-5.53	-5.57	-5.62	-5.52
Ferrous & non Ferrous.	-10.61	-10.49	-10.82	-9.97	-9.53	-3.09	-3.17	-3.19	-2.97	-2.90
Chemical Products.	-8.44	-8.51	-8.15	-8.47	-8.36	-2.40	-2.40	-2.40	-2.48	-2.50
Oth.Energy Intensive.	-5.35	-5.38	-5.34	-5.46	-5.33	-1.55	-1.63	-1.60	-1.58	-1.55
Electronic Equipment.	-1.72	-1.73	-1.48	-1.58	-1.23	-0.38	-0.39	-0.41	-0.36	-0.26
Transport Equipment.	-2.05	-1.95	-2.48	-2.07	-1.68	-0.51	-0.51	-0.54	-0.59	-0.45
Oth.Equipment	-5.82	-5.80	-5.63	-5.54	-5.19	-1.64	-1.69	-1.70	-1.59	-1.49
Oth.Manufacturing	-4.46	-4.41	-4.29	-4.30	-3.94	-1.13	-1.14	-1.18	-1.11	-1.00
Construction.	-2.35	-2.37	-2.28	-2.42	-2.43	-0.69	-0.68	-0.69	-0.71	-0.72
Food Industry.	-0.98	-1.44	0.20	-2.56	-2.75	-0.50	-0.36	-0.37	-0.89	-0.83
Trade & Transport.	-1.99	-2.03	-1.85	-2.18	-2.12	-0.53	-0.51	-0.52	-0.59	-0.55
Textile Industry.	-2.91	-2.90	-2.51	-3.33	-3.18	-0.79	-0.74	-0.77	-0.95	-0.81
Oth.Market Services.	-1.72	-1.73	-1.70	-1.91	-1.58	-0.45	-0.41	-0.44	-0.59	-0.48
Non Market Services.	-0.56	-0.59	-0.55	-0.69	-0.69	-0.13	-0.11	-0.12	-0.19	-0.17

Source : GEM-E3

In both profiles the Per Capita Convergence scenarios display the higher cost of achieving the emission reductions in terms of GDP, while the least cost adjustment is produced by the MS3 scenario. This difference is attributed to the different volume of income transfers that each scenario implies for the developing regions. In particular in the MS3 scenario most developing regions are favoured by a more abundant endowment of quotas which combined with the more extensive low cost abatement opportunities results in a substantial availability of quotas for sale in international markets. The additional income generated by the quotas sales is partly used on consumption readjusting demand for imported and domestically produced goods to higher levels. Developed regions facing a higher demand for their products partly compensate the losses incurred by the imposition of the emission constraint. On the other hand Per Capita Convergence scenarios imply a large quotas endowment to the developed regions implying higher adjustment costs to the non-Annex-B countries. Import demand by non-Annex-B countries falls leading this way to a substantial deterioration of the trade balance of the Annex B countries.

Changes in Sectoral Activity.

Adjustment to the emission constraint involves substitution away from commodities, the use of which (either in intermediate use or in final consumption) generates greenhouse

emissions. This favours other production factors including labour, capital and mostly non-energy intermediate consumption. It also encourages consumption of non-energy goods and services, in the case of households. Since substitution cannot be perfect given the technical production possibilities and the preferences of the consumer the agents would face higher overall costs.

As expected the energy sectors at a world level play the most important role in the re-adjustment process. In the S650e profile the different endowment scenarios present similar effects on the energy sectors. Coal production is substantially reduced due to the high increase in coal prices induced by the carbon value. Oil demand is also affected especially in some non-Annex B countries where oil is used to a considerable extent for substitutable purposes (power generation and industry). Electricity use to the extent that it is produced from coal and gas also experiences substantial price increases and subsequent reductions in demand. Natural gas on the other hand being a substitute of other fossil fuels is affected less implying an increase in its share as an energy source. These effects are more pronounced in S550e, due to the higher carbon values.

Apart from the energy sectors it is the energy intensive sectors that contribute most to the economic adjustment. Among these sectors the metal and chemical industries register the sharper output reductions in both profiles. This is attributed both to the heavy dependence of the metal industry on solid fuels and to the additional costs imposed to the chemical industry as a result of its HFC and N₂O emissions. Apart from these overall effects, energy intensive industries also experience important geographical shifts as a result of the imposition of the emission constraints. This takes broadly the form of a decrease in the share of some key developing countries such as China and India as well as the important energy exporting regions and a subsequent increase in the share of highly developed economies. In the baseline the most energy intensive components of these industries tended to concentrate in areas where either low cost coal and electricity was available (the case of China and India) or where internal energy prices were low due to deliberate policy (very low taxation or preferential pricing) which is the case for major energy exporting regions such as the Middle East and the Former Soviet Union. The imposition of a common carbon value tends to reverse dramatically such comparative advantages with other regions that have already adjusted to higher energy prices and use fossil fuels much more sparingly proving to be more resilient in the face of increased fuel costs.

Changes in agriculture and related industries (food industry and textiles) are of particular interest since they seem to be very dependent on the re-distribution of income across regions. In both profiles the most pronounced reduction in agricultural production and related industries is presented in the per capita convergence scenarios where endowments are smaller for developing regions. In particular these scenarios imply the weaker income transfers to less developed regions. Lower quota sales in developing regions entail deterioration on their current account reducing their ability to import. Given that the marginal propensity to consume food and textiles in these regions is high it is imports of this type of good that registers the most pronounced effect. Thus it is the agricultural production of the developed regions that registers the highest reductions since demand from non-Annex-B countries deteriorates significantly.

The impact on the services and transport equipment industry is dominated by the changes occurring at the structure of households' consumption. This is the case of transport equipment where the cost of using transportation vehicles increases inducing households to reduce their consumption.

Macroeconomic Implications at the Regional Level.

As mentioned earlier the index used to evaluate the consequences of alternative emission quota endowments is welfare. This index was preferred (instead of GDP) because it allows taking into account the beneficial impacts that an increase in imports entails to the consumer

(household). In particular the income produced through selling of quotas allows a country not only to increase investment and productive capacity but to increase imports of goods and services as well. This increase in imports entailing a loss in GDP clearly benefits consumers who treat imported and domestically produced goods in the same manner (Armington hypothesis).

Before undertaking a presentation of the welfare implications of the different scenarios on the different regions of the world it is worth looking briefly at the quotas endowments that each scenario entails for each region in conjunction with their baseline emissions.

Table 23: Endowments to Baseline Emissions (2025).

	550 ppmv					650 ppmv				
	MS1	MS2	MS3	PCC2050	PCC2100	MS1	MS2	MS3	PCC2050	PCC2100
USA	0.41	0.44	0.33	0.54	0.67	0.70	0.67	0.63	0.68	0.85
Canada	0.38	0.41	0.32	0.43	0.51	0.55	0.53	0.52	0.54	0.64
Enlarged EU	0.55	0.57	0.48	0.58	0.66	0.72	0.71	0.69	0.73	0.83
CIS + Other Europe	0.52	0.54	0.46	0.53	0.62	0.69	0.69	0.66	0.67	0.78
Japan	0.56	0.58	0.49	0.59	0.66	0.73	0.71	0.70	0.74	0.84
Oceania	0.45	0.48	0.39	0.50	0.58	0.63	0.62	0.60	0.63	0.73
Latin America	0.67	0.65	0.79	0.70	0.68	0.82	0.82	0.90	0.88	0.86
Africa	0.95	0.93	0.93	0.91	0.70	0.98	0.98	0.98	1.14	0.88
Middle East	0.51	0.51	0.54	0.54	0.55	0.62	0.78	0.71	0.68	0.70
India	0.92	0.92	0.81	0.79	0.65	1.00	1.00	1.00	1.00	0.82
Rest of South Asia	1.00	1.00	1.00	1.43	0.97	1.00	1.00	1.00	1.80	1.23
China	0.70	0.65	0.90	0.62	0.63	0.89	0.89	0.93	0.79	0.79
South East Asia	0.73	0.74	0.64	0.62	0.58	0.91	0.91	0.92	0.79	0.73

Source: GEM-E3

Values greater than 1 indicate additional emission rights compared to baseline emissions. In the S650e profile, relatively abundant emission quotas are present only in the per capita convergence scenarios and concerns some of the poorest regions in the world, namely the Rest of South Asia and Africa. In the highly constraining S550e profile all regions receive small endowments compared to baseline emissions, apart from Rest of South Asia in the PCC2050 scenario. The largest quotas endowments for the developed regions are found in the Per Capita Convergence cases, while the MS3 scenario seems to be the most stringent.

A good indicator of the potential for cost effective emission reductions is given by the simulated abatement for the different scenarios. Table 24 depicts the least-cost allocation of the abatement effort for all scenarios.

Table 24: Percentage Emission Reductions by Region (2025).

	550 ppmv					650 ppmv				
	MS1	MS2	MS3	PCC2050	PCC2100	MS1	MS2	MS3	PCC2050	PCC2100
USA	-37.5	-37.2	-38.1	-36.2	-35.0	-17.9	-17.9	-18.0	-17.9	-17.7
Canada	-37.4	-37.3	-37.5	-36.7	-35.9	-19.1	-19.2	-19.2	-19.2	-19.1
Enlarged EU	-24.6	-24.5	-25.0	-24.0	-23.3	-11.1	-11.1	-11.2	-11.2	-11.1
CIS + Other Europe	-52.3	-51.6	-53.8	-51.4	-48.9	-31.0	-31.0	-31.2	-31.1	-30.4
Japan	-18.9	-18.7	-19.0	-18.4	-17.8	-8.4	-8.5	-8.5	-8.5	-8.4
Oceania	-29.7	-29.8	-29.2	-29.6	-29.1	-13.9	-13.9	-14.0	-14.1	-14.0
Latin America	-21.7	-21.6	-21.0	-21.0	-20.5	-9.1	-9.1	-9.1	-9.1	-9.1
Africa	-30.5	-30.7	-31.0	-30.1	-31.0	-13.0	-13.0	-13.0	-12.9	-13.0
Middle East	-43.7	-43.7	-43.6	-42.8	-42.1	-22.1	-21.3	-21.7	-21.8	-21.7
India	-30.6	-30.7	-35.3	-36.2	-43.0	-24.0	-24.1	-24.1	-24.1	-25.3
Rest of South Asia	-32.2	-32.2	-32.1	-28.4	-31.7	-16.0	-16.0	-16.0	-14.6	-15.6
China	-46.5	-47.1	-43.5	-46.9	-46.1	-24.6	-24.7	-24.7	-24.8	-24.6
South East Asia	-26.8	-26.7	-27.1	-26.9	-26.5	-11.2	-11.2	-11.2	-11.4	-11.4

Source: GEM-E3

In broad terms, major energy exporters have very considerable CO₂ reduction potential as their baseline energy consumption patterns favour energy intensity through fossil fuel prices.

They also have a very high potential for reduction of non-energy related greenhouse gas mostly because of highly cost effective options for reducing methane emissions associated with primary hydrocarbon production. On the other hand in developed regions energy related CO₂ emissions can only be reduced at a relatively high cost since most of the easier options have been exhausted under the weight of higher fuel prices and taxation.

The combination of endowments as provided in the scenarios, baseline emission projections, the relative ease of abatement and the carbon value as it emerges from the equilibrium in the emission quotas market produces a value that represents a transfer of income to net sellers of quotas. The magnitude of this transfer represents the initial “shock” to the different economies, which weighed against abatement costs and the costs of re-adjustment to a new equilibrium arising from relative price movements for all flows in the economy, finally determines the welfare implications of the different scenarios. This initial “shock” is particularly important and closely correlates with the ultimate costs and benefits to the participants in the abatement effort implied by the scenarios.

Table 25: Purchase/Sales of Emission Quotas as % of GDP (2025).

	550 ppmv					650 ppmv				
	MS1	MS2	MS3	PCC2050	PCC2100	MS1	MS2	MS3	PCC2050	PCC2100
USA	-0.62	-0.52	-0.87	-0.26	0.05	-0.07	-0.08	-0.10	-0.37	0.06
Canada	-0.91	-0.81	-1.16	-0.71	-0.44	-0.18	-0.19	-0.20	-0.93	-0.56
Enlarged EU	-0.44	-0.43	-0.65	-0.40	-0.24	-0.07	-0.08	-0.09	-0.35	-0.13
CIS + Other Europe	1.08	1.55	0.02	1.12	2.51	-0.01	0.02	-0.12	-0.45	1.97
Japan	-0.25	-0.22	-0.32	-0.21	-0.14	-0.03	-0.04	-0.04	-0.16	-0.07
Oceania	-1.07	-0.94	-1.42	-0.82	-0.48	-0.18	-0.19	-0.21	-0.92	-0.48
Latin America	-0.55	-0.63	-0.02	-0.40	-0.49	-0.08	-0.08	-0.01	-0.11	-0.22
Africa	3.17	2.88	3.18	2.42	0.10	0.26	0.26	0.26	3.20	0.14
Middle East	-0.42	-0.47	-0.22	-0.28	-0.20	-0.25	-0.01	-0.12	-0.82	-0.64
India	6.75	6.66	5.01	4.35	2.18	1.35	1.35	1.37	6.82	2.02
Rest of South Asia	6.46	6.37	6.65	13.33	5.11	0.59	0.60	0.60	17.77	6.77
China	3.53	2.56	7.56	1.85	1.70	0.54	0.55	0.70	0.68	0.75
South East Asia	0.00	0.03	-0.62	-0.69	-0.92	0.03	0.03	0.05	-0.63	-0.90

Source: GEM-E3

Table 25 gives the value of this initial “shock” as a percentage of 2025 GDP in an attempt to measure its relative importance. In general it can be seen that developed regions are net purchasers of quotas. The picture for the other regions is more mixed. The net inflow in South Asia is very considerable in all cases and naturally highest in the Per Capita Convergence cases.

Before proceeding with a closer look at the welfare implications of the scenarios for the different regions it is worth demonstrating the close correlation between welfare gains/losses with the income inflows/outflows arising from the trading of quotas. The MS1 S550e is chosen for illustrative purposes but it is clear from the tables that the same with relatively minor variations holds for all scenarios.

Figure 23 presents the transfers implied by the trading of quotas as obtained from the previous table against the welfare gains/losses obtained at the new equilibrium. In most countries/regions the two impacts are proportional. There are however some exceptions that are worth pointing out because they help understanding the welfare change results that are presented later.

Figure 23: Change in Welfare and Net Sales of Quotas as % of GDP (MS1 – 2025)

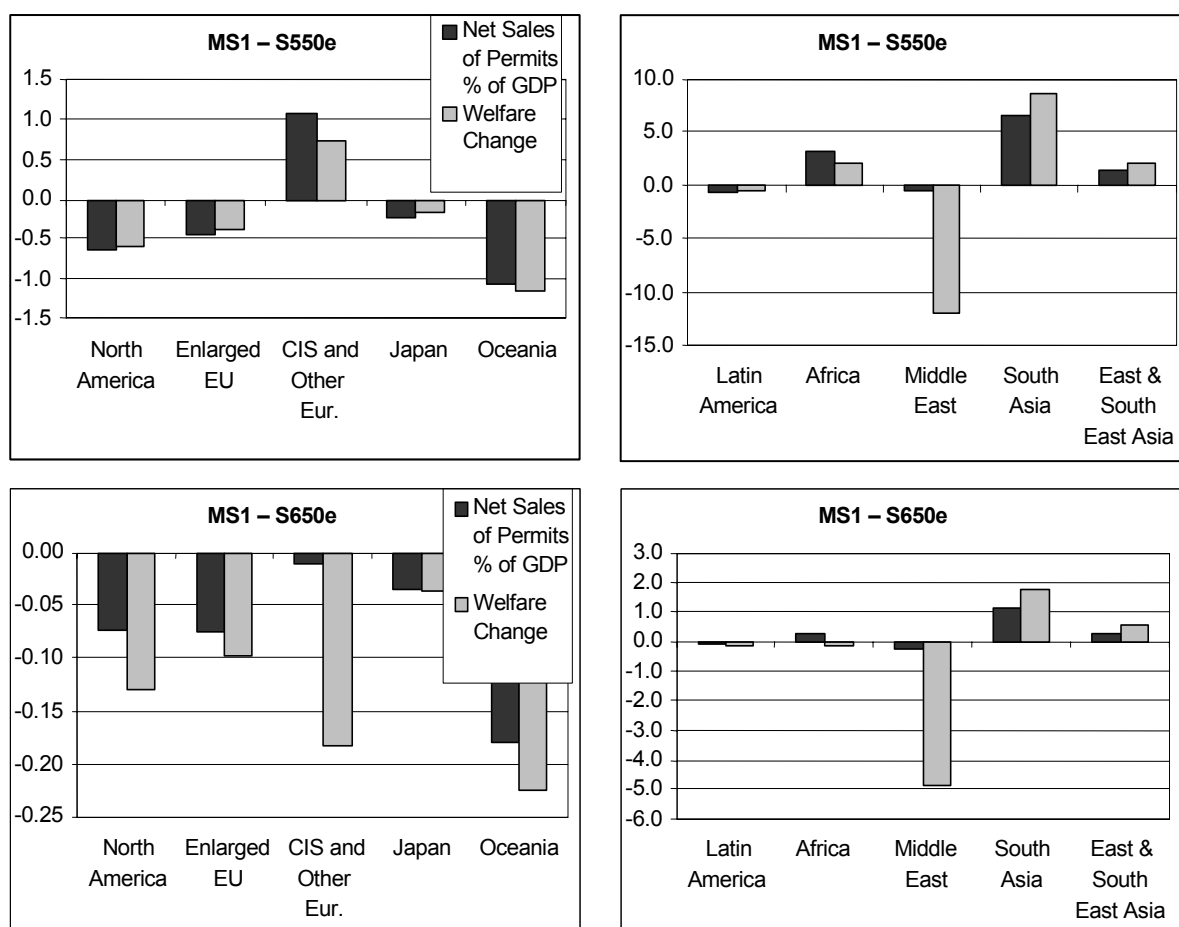

Source : GEM-E3

The most notable among them concerns the Middle East, which registers in both profiles the biggest losses in terms of welfare. This is mainly due to a deterioration of the terms of trade as the price of crude oil as the main export of the region falls. Similarly for the S650e profile the Former Soviet Union that is also a major crude exporter deviates from proportionality but to a much lesser degree because of a better diversification of its exports. India and to a lesser extent China also display a modest downward deviation which is linked more to falling export prices and increasing costs of some of their energy intensive sectors which in the baseline had gained substantial shares of the world market based on the availability of cheap coal (an advantage that in the scenario is severely curtailed). Opposite forces operate in the case of the “Rest of South Asia” region, which is characterized by low dependence on fossil fuels and can use the windfall of the sale of emission quotas to boost consumption with a multiplier effect.

Table 26 summarizes the impact of the scenarios on the welfare of the different countries/regions identified in the GEM-E3 model. The transfer implied by net sales of quotas leads to changes in international distribution of consumption. In particular consumers in countries, which sell emission quotas, see their disposable income increase and they use a part of this additional income to purchase consumption goods. Since welfare is primarily a function of consumption, a welfare increase occurs in regions that are net exporters of quotas. The regions that are negatively affected by the mitigation policy, in terms of welfare, are mainly the energy exporters while significant positive effects are registered in developing countries such as Rest of South Asia, India, Africa and China.

Table 26: % Changes in Welfare (2025).

	550 ppmv					650 ppmv				
	MS1	MS2	MS3	PCC2050	PCC2100	MS1	MS2	MS3	PCC2050	PCC2100
U.S.A.	-0.41	-0.38	-0.49	-0.31	-0.17	-0.08	-0.08	-0.09	-0.10	-0.06
Canada	-0.89	-0.84	-0.98	-0.85	-0.65	-0.22	-0.22	-0.23	-0.26	-0.20
Enlarged EU	-0.40	-0.38	-0.44	-0.43	-0.30	-0.10	-0.10	-0.10	-0.12	-0.08
CIS + Other Europe	0.26	0.66	-0.76	0.21	1.45	-0.17	-0.12	-0.28	-0.30	0.26
Japan	-0.16	-0.16	-0.15	-0.20	-0.15	-0.04	-0.03	-0.04	-0.06	-0.04
Oceania	-1.16	-1.08	-1.34	-1.07	-0.74	-0.23	-0.23	-0.25	-0.27	-0.18
Latin America	-0.45	-0.61	0.43	-0.43	-0.52	-0.11	-0.09	-0.07	-0.13	-0.13
Africa	2.10	1.51	2.03	1.53	-0.28	-0.12	-0.10	-0.10	0.10	-0.31
Middle East	-11.98	-12.60	-10.22	-11.64	-11.54	-4.86	-3.16	-3.96	-4.27	-4.13
India	8.58	8.50	7.33	6.57	3.57	2.99	3.01	3.04	2.94	1.29
Rest of South Asia	8.65	8.45	9.15	11.56	7.30	-0.11	-0.10	-0.08	2.96	0.81
China	3.78	2.70	7.07	1.83	1.73	0.87	0.90	1.12	0.20	0.26
South East Asia	0.42	0.36	-0.06	-0.91	-1.28	0.19	0.20	0.23	-0.13	-0.21

Source: GEM-E3

In both profiles and in all scenarios examined Middle East registers the most pronounced negative welfare impacts. This is attributed to the fact that this region sustains a substantial deterioration in its terms of trade in all scenarios. In addition to that the Middle East is a net buyer of quotas. The energy exporting regions, Oceania and Canada also registers negative welfare impacts in most scenarios. Australia being a major coal exporter becomes a large purchaser of emission quotas in order to adjust to the emission constraint and therefore experience high welfare losses.

Enlarged EU is less affected by the abatement scenarios and among the multi stage scenarios this region is indifferent as they result in very similar net purchases of quotas and the welfare impacts are of the same order of magnitude. United States and Canada suffers relatively minor welfare losses in the PCC2100 scenario, while they are rather severely affected in the multi stage cases where the rapid reductions in endowments generate large income transfers in the form of quota purchases.

The regions that benefit most in terms of welfare are the Rest of South Asia and India. These regions are net exporters of quotas in all cases. High positive welfare impacts are also presented in regions such Africa that includes some of the poorest regions in the world. For these regions the MS3 and the PCC2050 scenarios offers the best welfare prospects while the PCC2100 scenario the worst. This finding is dominated by the fact that MS3 and the PCC2050 scenarios offer the largest endowment of quotas in both profiles.

4.2.4. Model based quota endowment scheme.

This section presents a quota endowment (referred as ENDO hereafter), which induces a neutral welfare impact to the developing countries (zero welfare change) and a uniform welfare change to the developed. This endowment is endogenously determined (i.e. the model is solved for the emission quotas endowment that satisfies the above conditions) and relates to the S550e profile.

- *Emission quotas endowment.*

The ENDO emission quotas endowment allows taking into account several country specific characteristics. These are:

- The preponderance of energy and energy intensive industries in the economy of certain regions.
- The dependence of the production sectors of an economy in trade variations.

The changes in emission quotas required to produce the welfare impacts mentioned above are presented in Table 27. Overall the ENDO endowment scheme favours regions that exhibited high welfare losses in the previous scenarios examined (i.e. the energy exporting regions) and grants fewer emission quotas to the Asian economies that exhibited considerable welfare gains (see Table 28). The quotas endowment implied by the ENDO scenario is quite similar to the one in the PCC2100 scenario. Compared to all the other scenarios Africa, India, China and Rest of South Asia receive considerably lower endowment in order to attain a neutral welfare impact. Enlarged EU, Canada and Oceania need to be endowed with additional quotas. Notable examples of the reallocation of emission quotas are the cases of Australia and Middle East. Australia is granted a considerable amount of emission quotas (12.4 per capita) in order to be compensated for the big negative impacts on output of non-ferrous metals, iron and steel, and coal sectors. Similarly emission quotas per capita in the Middle East nearly doubles indicating the amount of the additional income needed to compensate the losses from the deterioration of its terms of trade.

Table 27: Comparison of ENDO quotas endowment with the Multi-Stage and Per Capita Convergence scenarios (%Changes in 2025)

	MS1	MS2	MS3	PCC2050	PCC2100
<i>Africa</i>	-30.9	-30.9	-30.9	-26.8	-1.0
<i>Oceania</i>	65.7	56.5	93.6	49.9	28.8
<i>Canada</i>	83.1	72.4	116.0	63.2	38.4
<i>Enlarged EU</i>	0.4	0.3	0.6	0.3	0.2
<i>China</i>	-18.3	-12.1	-36.8	-8.5	-9.3
<i>Former Soviet Union</i>	1.7	-3.1	13.8	-0.9	-14.9
<i>India</i>	-40.0	-40.0	-31.8	-30.5	-15.6
<i>Japan</i>	-12.6	-16.4	-0.6	-16.8	-26.1
<i>Mediterranean</i>	-4.4	4.9	0.7	-3.6	11.4
<i>Mexico_Brazil</i>	18.7	16.9	-7.5	11.0	12.8
<i>Middle East</i>	66.0	68.0	58.0	58.7	54.3
<i>Other Latin America</i>	3.5	16.4	4.7	3.0	9.4
<i>Rest of East Asia</i>	-1.1	-1.8	13.1	16.5	24.7
<i>Rest of South Asia</i>	-33.3	-33.3	-33.3	-53.2	-31.4
<i>Rest of the World</i>	-9.0	-9.0	13.6	-4.9	14.8
<i>USA</i>	60.2	47.5	100.4	20.9	-2.3

Source: GEM-E3

Compared to the other scenarios in the S550e profile the ENDO scenario presents one of the highest GDP reductions at a world level (-2.93%). To a large extent this is due to the different utilization of the proceeds from quota sales by the different regions. In particular developing regions characterized by high marginal propensity to consume use the additional revenues from the sales of quotas to consume goods keeping demand at higher levels compared with scenarios that imply weak income transfers. Developed regions on the other hand are characterized by high marginal propensity to save. Thus the net result in the ENDO case is an overall increase in the global savings rate inducing lower activity at a world level. The large reductions in the GDP imply lower emissions realized and therefore a reduced need for abatement, resulting in a lower carbon value (44.6 €99 t/CO₂e in 2025).

From a sectoral point of view agricultural and related products register the largest reductions compared to all scenarios previously examined. As in the per capita convergence scenarios this is attributed to the substantial income loss of the developing regions induced by the weaker income transfers (compared to the Multi-Stage scenarios). Thus agricultural products having a large weight in the consumption pattern of these regions are affected more. Energy sectors on the other hand exhibit lower reductions from any other scenario in the S550e profile. To a great extent this indicates the implications of the income redistribution to the

carbon value. The lower overall activity level that this scenario implies leads to lower carbon values inducing ultimately lower additional costs to the energy sectors.

Table 28: Emission quotas of ENDO scenario (GtCO₂e), S550e.

	<i>Emission Rights (% dif. from Baseline Emissions)</i>			<i>Emission Rights Per Capita (2025).</i>					
	2015	2020	2025	ENDO	MS1	MS2	MS3	PCC2050	PCC2100
<i>Africa</i>	-0.11	-0.19	-0.31	1.7	2.5	2.5	2.5	2.3	1.7
<i>Oceania</i>	-0.03	-0.12	-0.25	12.4	7.5	7.9	6.4	8.2	9.6
<i>Enlarged EU</i>	-0.13	-0.08	-0.14	9.9	6.9	7.2	6.1	7.3	8.3
<i>Central America</i>	-0.11	-0.17	-0.25	4.9	4.2	4.2	5.4	4.5	4.4
<i>Canada</i>	-0.05	-0.14	-0.30	14.5	7.9	8.4	6.7	8.9	10.5
<i>China</i>	-0.19	-0.28	-0.43	4.0	4.9	4.6	6.4	4.4	4.5
<i>Former Soviet Union</i>	-0.20	-0.31	-0.47	8.4	8.3	8.7	7.4	8.5	9.9
<i>India</i>	-0.19	-0.27	-0.45	2.0	3.3	3.3	2.9	2.9	2.4
<i>Japan</i>	-0.26	-0.39	-0.51	6.1	6.9	7.2	6.1	7.3	8.2
<i>Middle East</i>	0.22	0.07	-0.15	6.1	3.7	3.7	3.9	3.9	4.0
<i>Mediterranean</i>	-0.03	-0.12	-0.22	3.1	3.3	3.0	3.1	3.2	2.8
<i>Rest of East Asia</i>	-0.11	-0.17	-0.28	4.2	4.2	4.2	3.7	3.6	3.3
<i>Rest of the World</i>	-0.02	-0.15	-0.26	3.1	3.4	3.4	2.8	3.3	2.7
<i>Rest of South Asia</i>	-0.10	-0.18	-0.33	1.1	1.6	1.6	1.6	2.3	1.6
<i>Latin America</i>	-0.09	-0.15	-0.24	2.4	2.3	2.1	2.3	2.3	2.2
<i>USA</i>	-0.08	-0.18	-0.35	17.3	10.8	11.7	8.6	14.3	17.7

Source: GEM-E3

In terms of emissions per capita the ENDO scenario is one of the least equitable considered in the project. Figure 24 presents the Lorenz curve implied by each scenario. The straight line indicates a perfectly egalitarian situation where the initial endowment of quotas implies equal per capita emissions. Three groups are identified in Figure 24:

- i/ the Multi-Stage scenarios that imply the more equal distribution of emission quotas
- ii/ the ENDO and PCC2100 scenarios that provides the most unequal distribution and
- iii/ the PCC2050 scenario that lies in the middle.

These observations are confirmed by the Gini coefficients, which drop from 0.43 in ENDO to 0.28 in the MS3 scenario.

Figure 24: Lorenz Curves (2030)

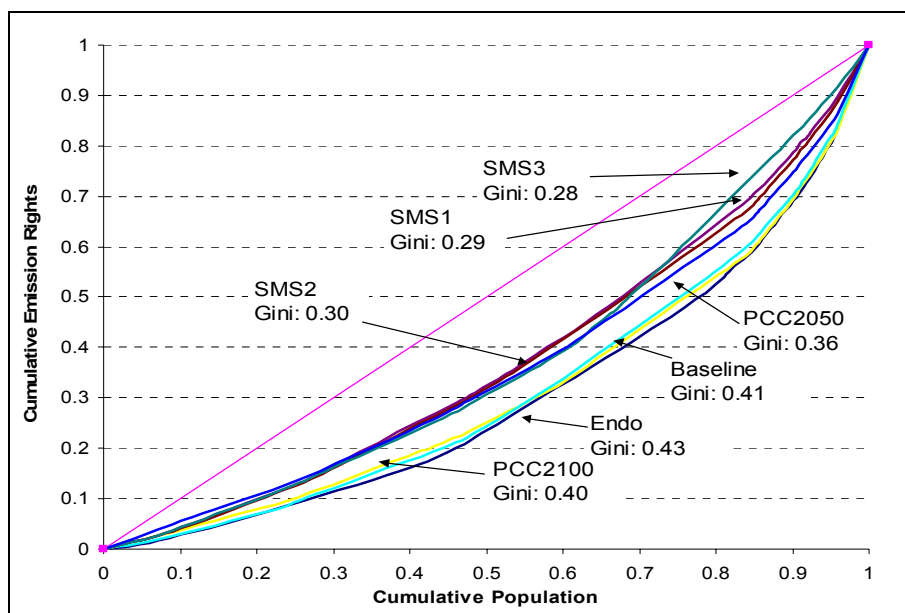

Source : GEM-E3

4.2.5. Conclusions

The key conclusions emerging from the analysis of the different quota endowments schemes are presented below:

- Within the context of a general equilibrium model the different initial quota endowments entail different carbon values in highly constraining cases (S550e). The more stringent reductions a scenario imply the more crucial is the role of the initial quota endowment.
- The cost of achieving the reductions (in terms of world GDP) ranges between -0.7 and -0.9 percent in 2030 for S650e and from -1.9 to -2.8 for S550e.
- The more redistributive scenarios produce more important GDP reductions by increasing the savings ratio on a global scale. On the other hand they also tend to produce the lower carbon values.
- The multi-stage scenarios provide in both profiles better welfare prospects for developing regions as they imply higher income transfers.
- The dominant redistributive element in the scenarios consists of the opportunities they provide for income transfers in the form of net quota sales/purchases. The sectors that were found to be more sensitive to such income reallocations are agriculture, textiles and food products.

4.3. Long term abatement costs and emission trading with the FAIR model

In this section the different climate regimes for differentiation of future commitments are put in a longer term perspective and compared to the 2025 and 2050 horizon, on a global and regional scale with respect to domestic abatement, emission trading and abatement costs.

The modelling framework relies on the linking of the FAIR 1.1 model with the TIMER 1.0/IMAGE 2.2 model. The emission trade and costs model of FAIR 1.1 is used to calculate the international carbon value, the domestic and external abatements and the abatement costs of the climate regimes explored (den Elzen and Both, 2002; Lucas, 2003). This has been done on the basis of CO₂ Marginal Abatement Costs (MAC) curves derived from the TIMER energy model and non-CO₂ MACs from the GECS project. The energy model TIMER is used to provide a description of induced changes in the energy system and the contributions of the various CO₂ abatement options (de Vries et al., 2002; van Vuuren and de Vries, 2001). The land-use models of the integrated assessment model IMAGE 2.2 is used to prescribe regional information about forest sinks (IMAGE-team, 2001).

4.3.1. World prices and global effort

Figure 25 shows the international carbon value and the global effort rate on the basis of the selected climate regimes and emission profiles. The international carbon value for the S550e profile is much higher than for the S650e profile, which can be explained by: i/ the much larger emission reduction objective for the S550e profile and ii/ the exponential form of the global MAC curve with fast increasing prices for the higher emission reduction objectives.

Figure 25: The international carbon value (top) and the global effort rate (bottom) between 2000 and 2100 for the S550e (left) and S650e profile (right).

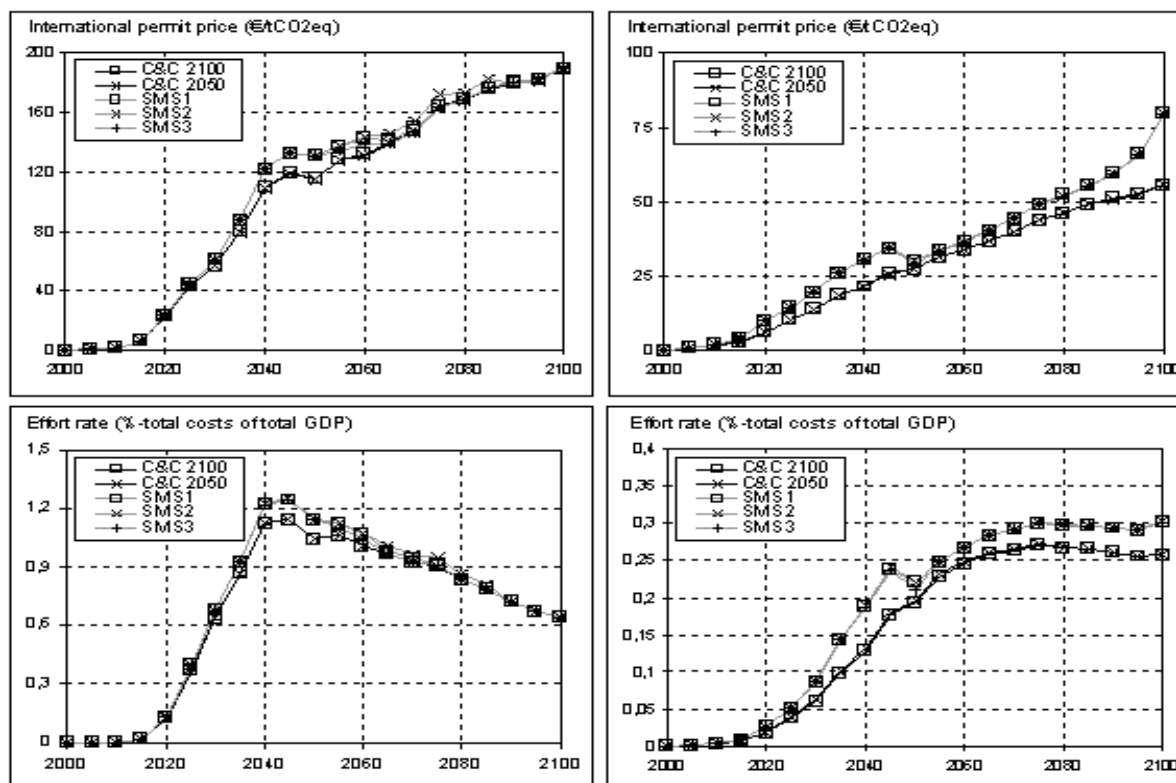

Source: FAIR 2.0/ TIMER 1.0

Over the period 2010-2050, the international carbon value for the S550e profile shows a strong increase, corresponding to the growing intensity of the required emission reductions. For the S650e profile the carbon value increases almost linearly due to a more gradual increase in the constraints. The international carbon value shows a continuous increase after 2050 for both emission profiles, despite the slow-down in the required reductions.

The international carbon value for the Per Capita Convergence cases remains somewhat below the carbon value for the Multi-Stage cases for both profiles during most of the century. This difference results from the participation of the non-Annex I regions in the emissions trading market. For the Per Capita Convergence cases all non-Annex I regions fully participate, whereas for the multi-stage cases participation increases in time. The non-participating non-Annex I regions have no commitments, and can therefore only participate through CDM projects, for which a lower accessibility of emission reduction options has been assumed.

For the S550e profile, the global effort rate increases substantially until 2040, after which it decreases gradually. This can be explained by a stronger increase in the global GDP than in the total abatement costs after 2040. For the S650e profile, the effort rate increases gradually and then stabilises after 2070. It does not however decrease as much as in S550e because of the continuously increasing carbon value.

4.3.2. Regional abatement and trading under the S550e and S650 profiles

The developments in emission trading can be explained by the combination of the differences in the global and regional emission reduction objectives with the differences in marginal abatement costs between regions. The international carbon value is mainly determined by the global emissions reduction efforts required, thus by the difference between the stabilisation profile and the baseline. Figure 26 and Figure 27 show the required emissions reductions compared to baseline levels on a regional level for the five climate regimes and both emission profiles. Negative reductions indicate the sellers of emission reductions, while the positive bars indicate the buyers.

The S550e profile:

The Annex I regions show very similar patterns as already shown for the relative emission reduction objectives. The non-Annex I regions show larger differences between regions, where Africa and South Asia and to a lesser extent South East & East Asia are sellers of quotas and Latin America and Middle East & Turkey buyers. In the short-term, significant reductions are needed for the current Annex I in all climate regimes. In the long-term, these reductions increase further, but the pattern of differences between the reduction levels of Annex I and non-Annex I regions remains similar. Along with the increase in the stringency of the regional emission reduction targets in the long-term, the share of domestic reductions also increases.

The PCC2100 case and to a lesser extent MS3 result in significantly different trade patterns than the other three climate regimes. For the PCC2100 case all Annex I regions except Oceania become sellers on the market, which is a result of their relatively low reduction objectives and higher reduction objectives, as compared to the other non-Annex I regions. The same holds for MS3 for Latin America in 2025.

Figure 26: Relative reductions compared to baseline in 2025 (top) and 2050 (bottom) for the S550e profile.

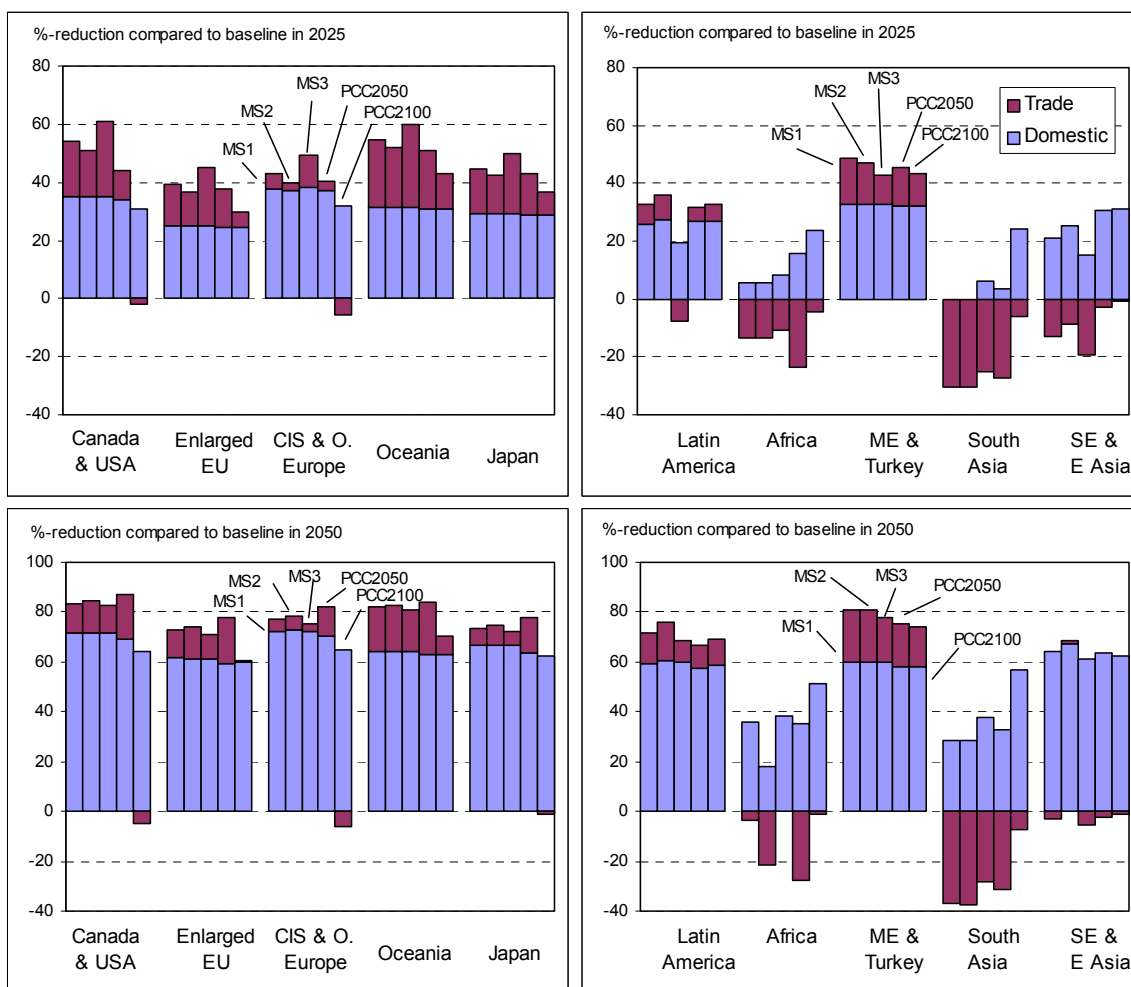

Source: FAIR 2.0/ TIMER 1.0

The S650e profile:

Compared to the S550e profile, relatively more emissions are traded in both the short and the long-term, while the net sellers and buyers remain unchanged. In the short-term, Africa and South Asia do not fully participate for the three Multi-Stage cases and can therefore only join emission trading through CDM projects. This results in a limited supply of emission quotas. In the long-term, these regions join the intensity target regime, which increases their supply on the international market.

The PCC2050 case results in large amounts of surplus emission endowments for Africa and South Asia, explaining their relatively large emission quotas supply. The large amount of surplus emission endowments results in a small endowment for the Annex I regions, and in a strong demand for emission quotas. The PCC2100 case is again completely different, with emissions supply for Canada & USA, CIS and Eastern Europe and even Japan.

Figure 27: Relative reductions compared to baseline in 2025 (top) and 2050 (bottom) for the S650e profile.

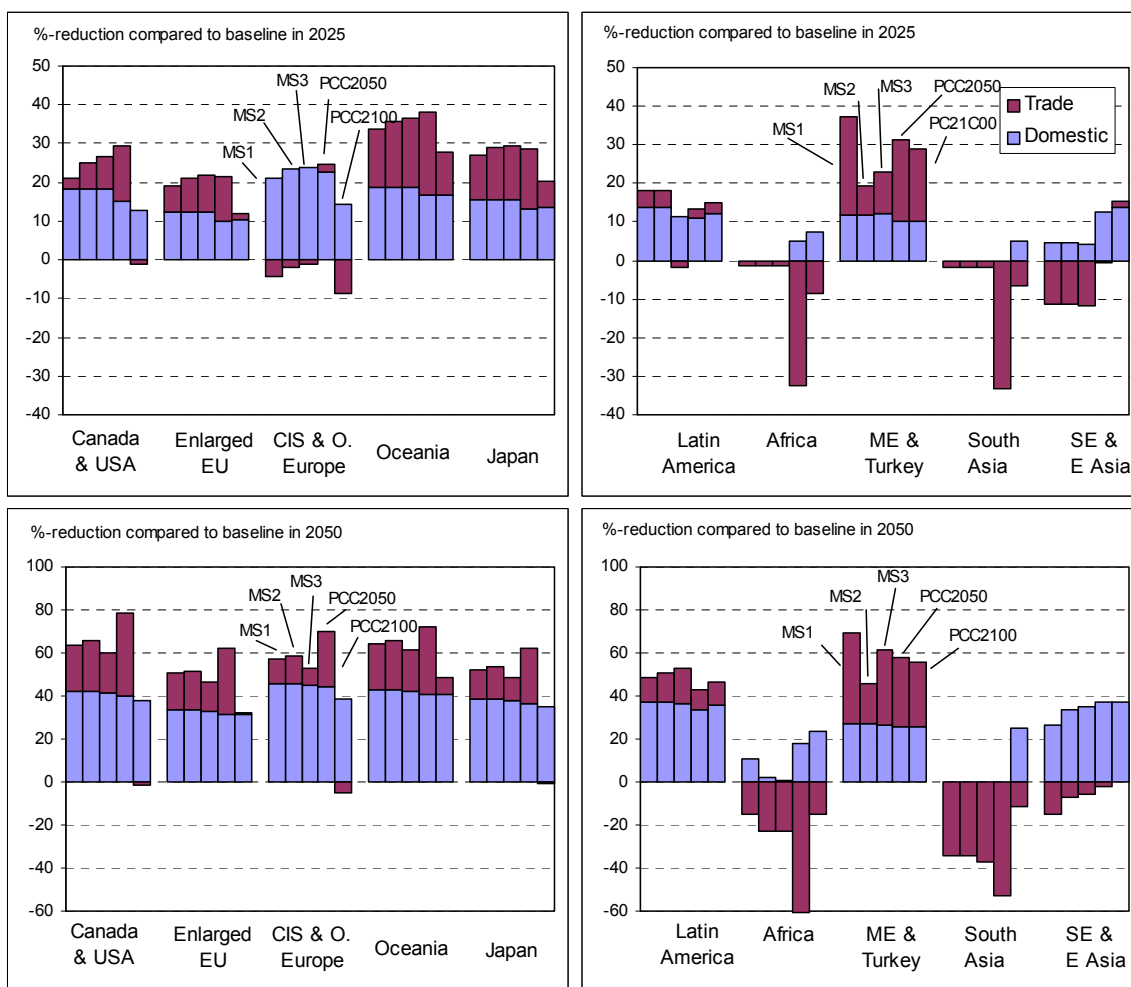

Source: FAIR 2.0/ TIMER 1.0

4.3.3. Financial flows

Figure 28 and Figure 29 show the financial flows between the different regions (in billion €) on the international quota market under the two global emission profiles. The capital flows are determined by multiplying the total trade volumes by the international carbon value. It thereby also gives an indication of the major buyers and sellers on the market and of the volumes traded.

The S550e profile

Except for PCC2100 case, the main buyers in the short-term are Canada & USA and Middle East & Turkey and to a lesser extent the Enlarged EU. The main sellers are South Asia and South East & East Asia and to a lesser extent Africa. In the long-term, the main buyers become Middle East & Turkey and Latin America, while Canada & USA remains a significant buyer, but to a lesser extent. The main suppliers remain more or less the same, while the share of South East & East Asia decreases, due to lower endowments. In the short-term, there is some emissions surplus available for Africa in the PCC2050 case, which increases the supply on the trading market.

More emissions are traded in the long-term than in the short-term, due to more stringent emission objectives, although this increase in traded volume is somewhat limited by the higher international carbon value and increased convergence in the marginal costs between regions

For the MS3 case, the traded volume and financial flows decline in the long-term, due to higher emission reduction objectives for the major supplying regions (South Asia and Africa) and lower objectives for the demanding regions (Annex I).

The traded volume and the financial flows for the PCC2100 case are significantly lower than for the other regimes; this can again be explained by the lower Annex I reduction objectives resulting in a lower demand. The higher emission reduction objectives for the low-income non-Annex I regions (Africa and South Asia) also decreases their supply capabilities.

Figure 28: Financial flows resulting from emission trading for the 10 regions in 2025 (top) and 2050 (bottom) under the S550e

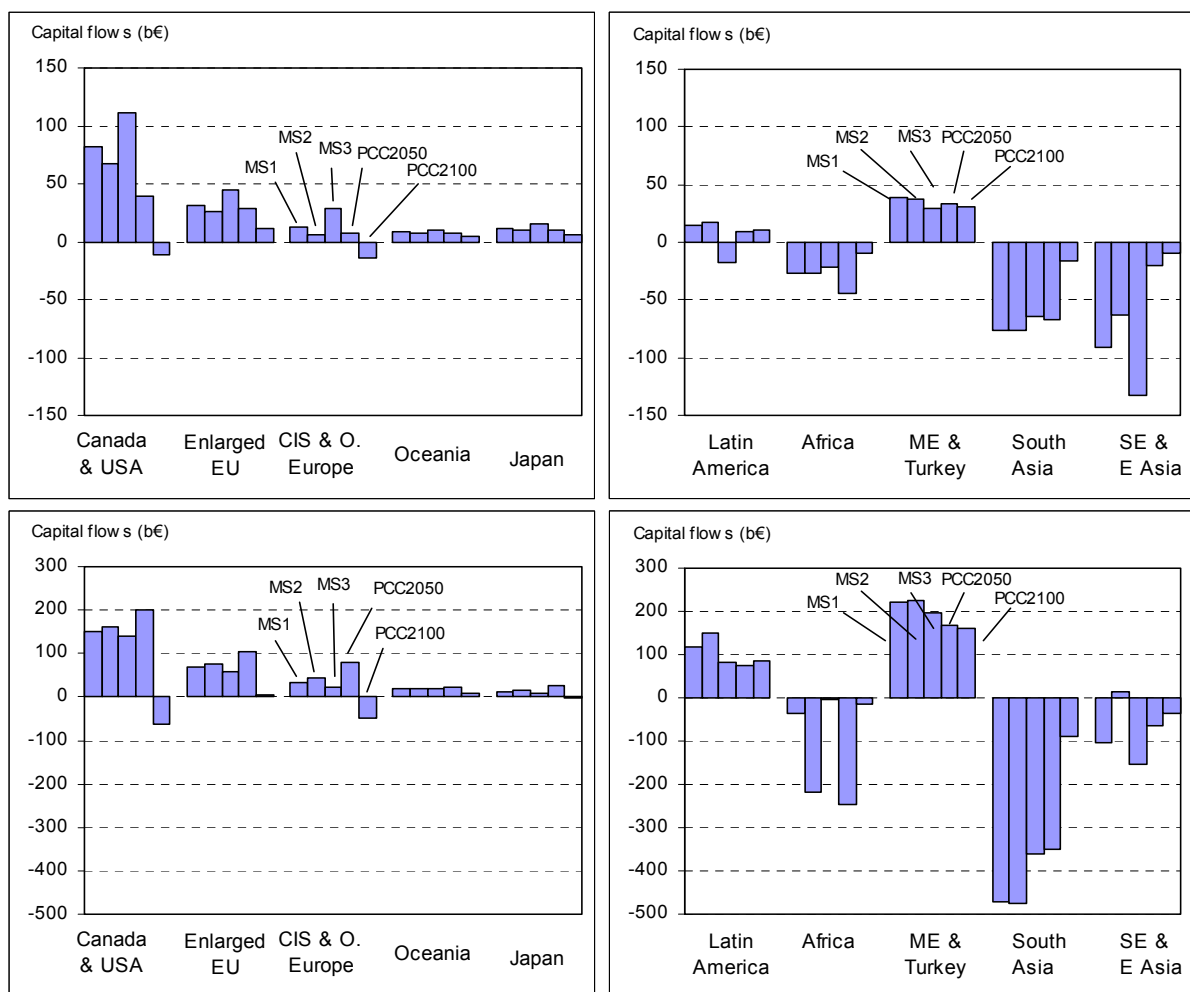

Source: FAIR 2.0/ TIMER 1.0

The S650e profile

Although the volumes traded under the S650e profile are higher than under the S550e profile, the financial flows are much smaller due to the lower international carbon value. Simultaneously, the trade pattern between the various cases is not much affected.

Figure 29: Financial flows resulting from emission trading for the 10 regions in 2025 (top) and 2050 (bottom) under the S650e

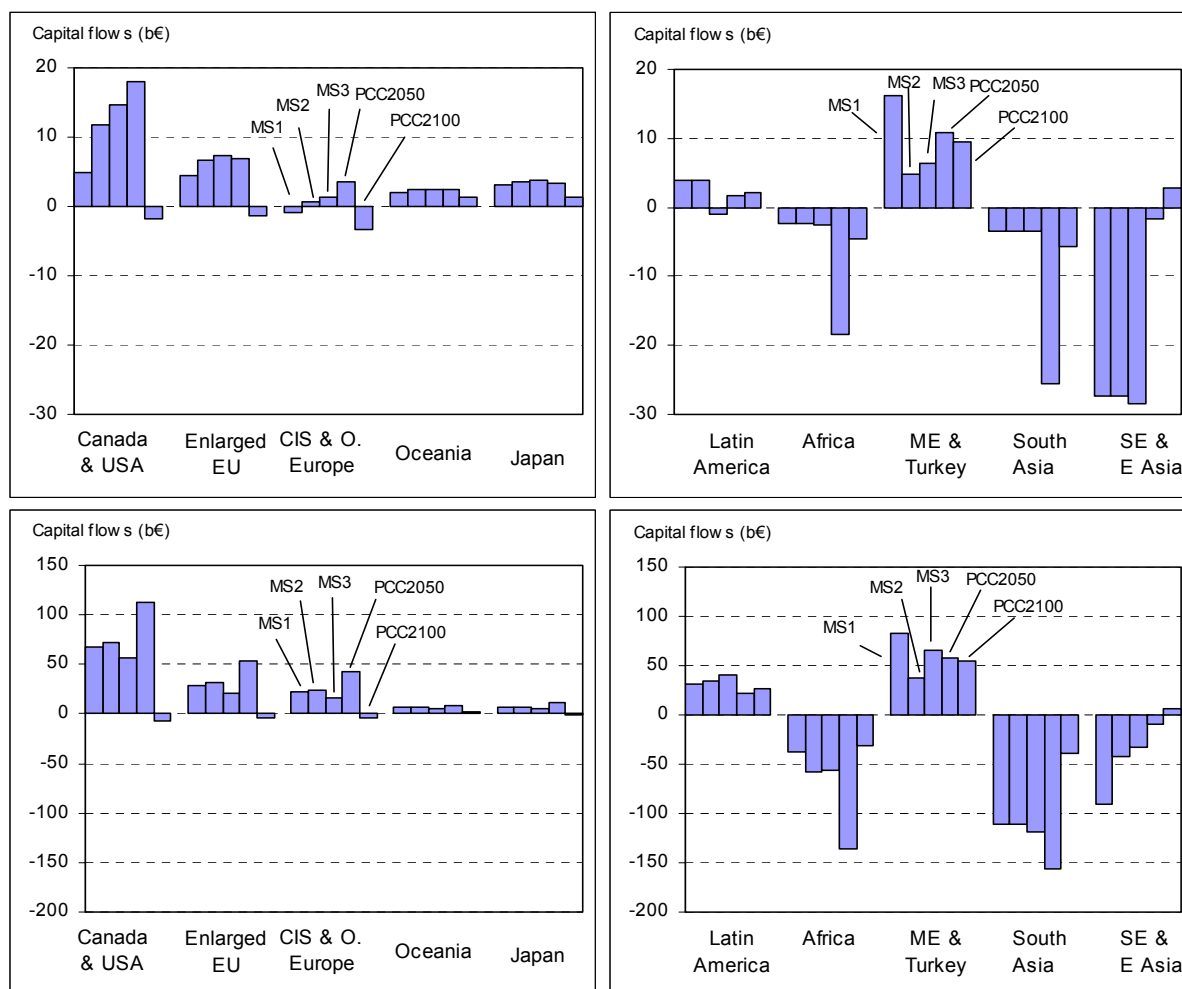

Source: FAIR 2.0/TIMER 1.0

4.3.4. Effort rates

The net regional costs or gains in the different regimes result from the costs of domestic abatement combined with the costs or gains from emission trading. These have been expressed as a percentage of regional GDP in PPP terms and give an indication of the relative economic effort in each region. The effort rate does not however include the macro-economic effects that can only be assessed in a general equilibrium framework. Figure 30 and Figure 31 show the effort rates for the S550e and S650e profiles for each of the five climate regimes explored.

The S550e profile:

The effort rates differ largely across the different cases and regions. This can be partly explained by the differences in regional traded volumes for the different cases and by differences in regional GDP.

Over the whole period, Middle East & Turkey is confronted with the highest effort rates, due to relatively high emission reduction objectives and a low GDP (in 2050 still lower than the 1990 Annex I per capita income). In the long-term, the emission reductions and thereby the

abatement costs of Latin America and CIS becomes much larger, which combined with their relatively low GDP also results in relatively high effort rates.

Figure 30: Effort rate for the 10 regions in 2025 (top) and 2050 (bottom) for the S550e profile.

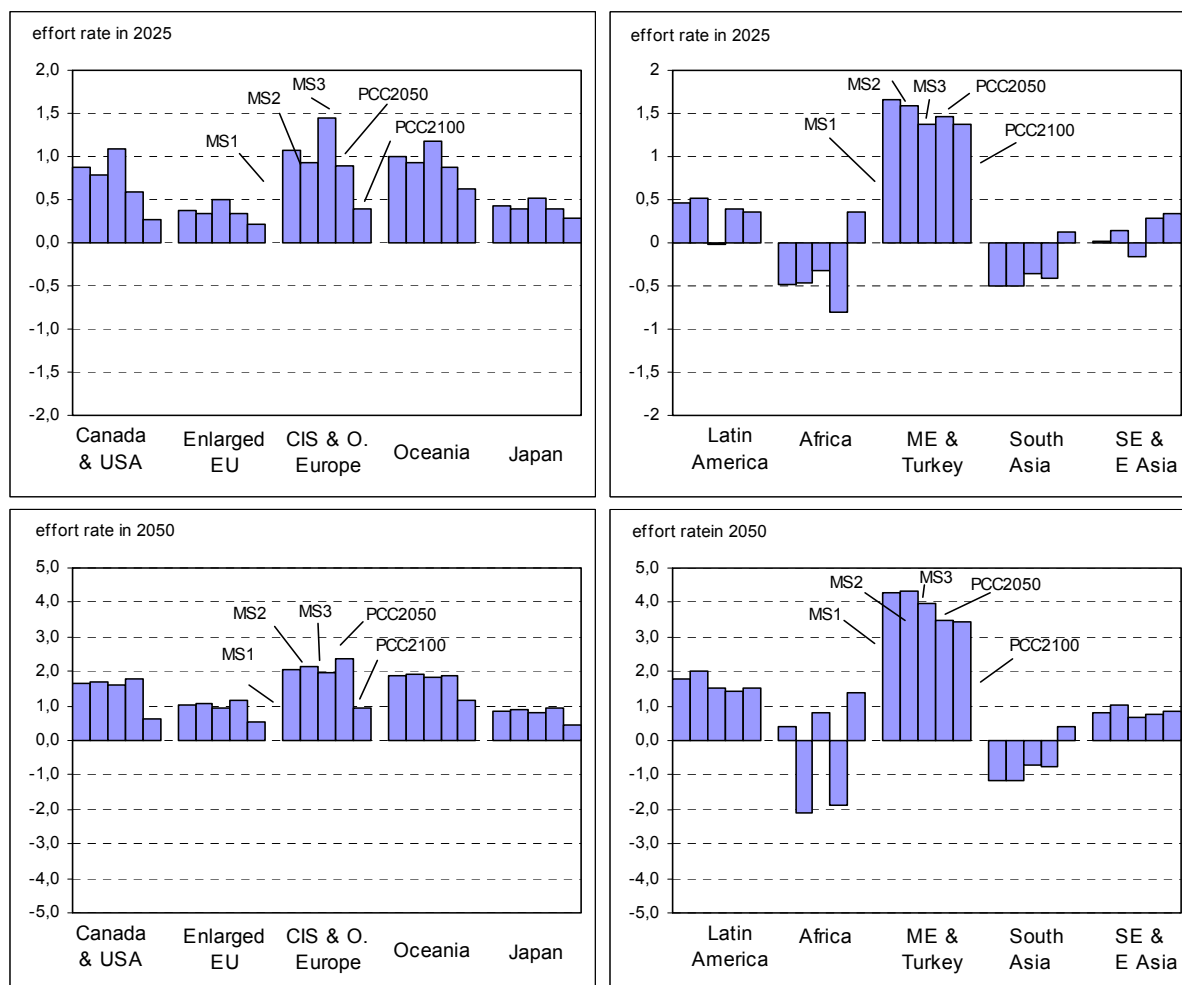

Source: FAIR 2.0/TIMER 1.0

Except for the PCC2100 case, South Asia shows net gains in all regimes, both in the short-term as the long-term. Its gains are the largest for the first two Multi-Stage cases. The effort rate of Africa, on the contrary, differs greatly between the various regimes in the long-term. These differences result from large changes in endowments for the various regimes and of the relatively low GDP, which magnifies the impacts on the effort rate.

Again, the PCC2100 case shows different results than the other four cases. All Annex I regions have lower effort rates than in all other cases, while for Africa and South Asia the PCC2100 case results in costs instead of gains. Also the MS3 case shows a similar pattern as before, i.e. more effort in the short-term for the Annex I regions, while less effort is required from Latin America, Middle East & Turkey and South East & East Asia. In the longer term, these effects are vanishing.

The S650e profile:

The differences in effort rates are much smaller in the S650e than in the S550e profile. For the three Multi-Stage cases, the low-income regions benefit more in the long-term due to their late entrance and consecutively larger endowment.

The large amounts of surplus emission endowments for Africa and South Asia in the PCC2050 case results in large gains. Combined with the relatively low GDP of this region this results in a very high negative effort rate.

Middle East & Turkey is again the region with the highest effort rate for both the long and the short-term. The region still buys a large share of its emission reduction objective abroad, making it relative expensive.

Figure 31: Effort rate for the 10 regions in 2025 (top) and 2050 (bottom) for the S650e profile.

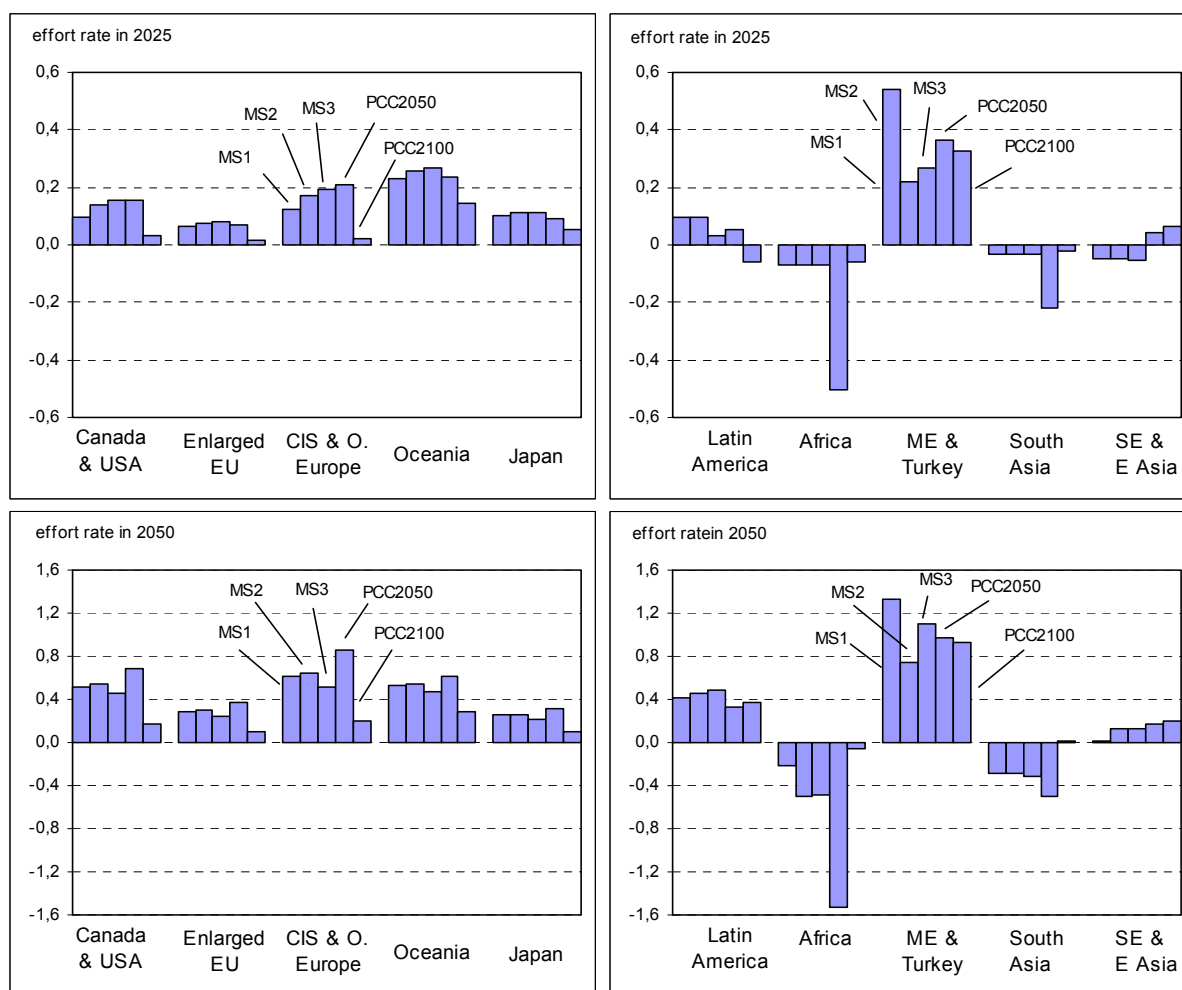

Source: FAIR 2.0/TIMER 1.0

4.3.5. Abatement action within the long-term energy system

This section presents in more detail the abatement actions within the energy system. There are no substantial differences between the different schemes for differentiation of future commitment schemes for a given emission profile: exceptions occur for the Multi-Stage cases in which not all regions participate fully during the whole period studied. Conversely, there are substantial differences between the S550e and S650e profiles and the following analysis concentrates on the implications of the two different stabilisation levels on the basis of the PCC2050 case. The climate policy scenarios in TIMER are simulated by introducing the carbon value calculated in FAIR, inducing a variety of changes in the energy system: increased investments into energy efficiency, fuel switches, changes in fuel trade patterns etc..

Figure 32 shows that the S550e profile leads to substantial changes compared to the baseline. Global primary energy use is reduced by more than 35% in 2050. Clearly, the reductions are not similar across the different energy carriers. The largest reductions occur for coal (70% in 2050, compared to baseline), with the remaining coal consumption being primarily used in electric power stations using carbon capture and storage. Reductions of oil and natural gas are 50 and 45%, respectively. Other energy carriers gain market share, in particular solar, wind and nuclear-based electricity and modern biomass⁴.

As the S650e profile requires less reduction in emissions, the changes in the energy system under this scenario are also less. Primary energy use is now reduced by 20%, while the reduction in coal consumption amounts to 50% of baseline consumption, resulting in 2050 consumption levels being slightly above current levels. The reduction in oil consumption is now 20% in 2050. As a result of a softer constraint, natural gas use is now higher than in the baseline until 2035. However, by that time further emissions reductions require natural gas to be replaced by zero carbon options, finally leading to a reduction of natural gas use of 10% in 2050.

Figure 32: Total world primary energy supply for baseline and stabilisation at 550 and 650 CO₂e (PCC2050 case)

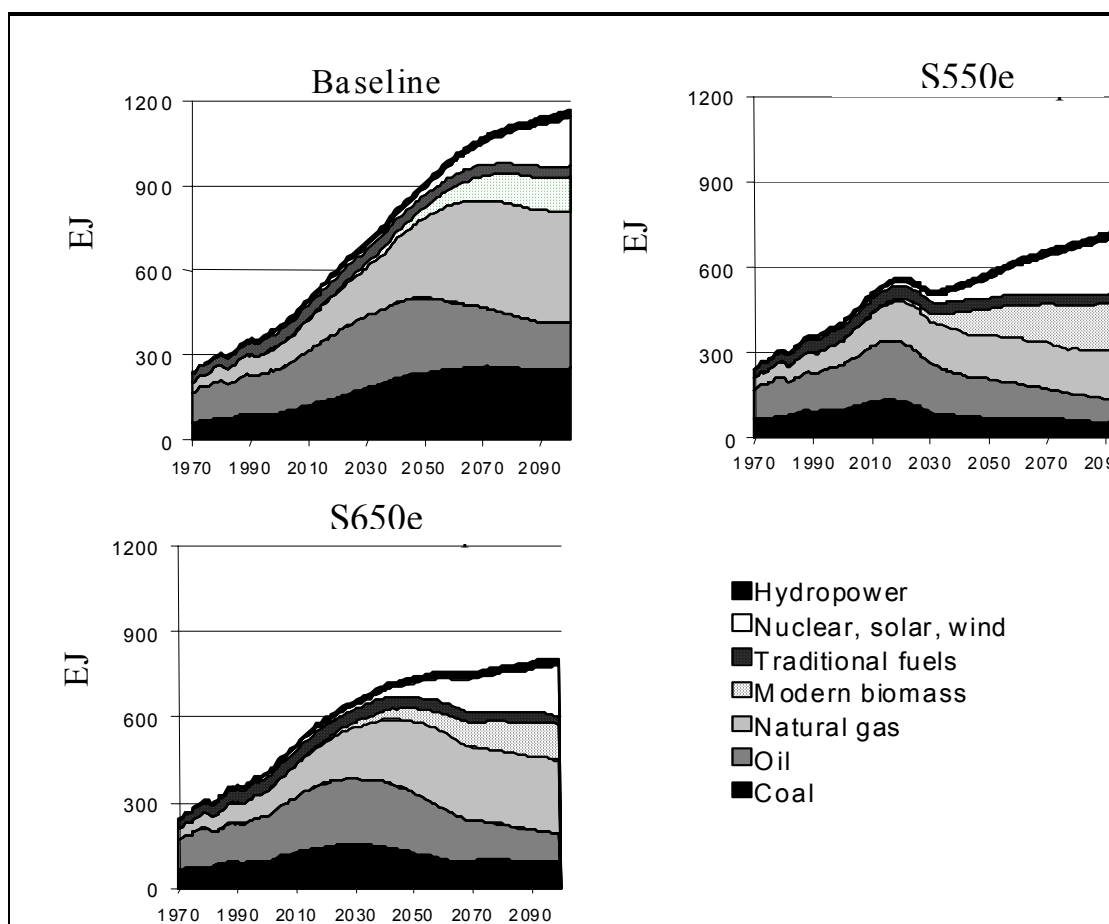

Source: TIMER 1.0

⁴ Modern biomass relates to gaseous or liquid fuels (commercially) produced from plants or trees. It differs from traditional biomass (gathered wood, straw, dung, charcoal, etc) use.

Figure 33 shows the contribution of different abatement options to the overall reduction objective.⁵ Over the whole simulation period, in particular in the first two decades, most reductions comes from energy efficiency improvement, in particular in non-Annex 1 regions. By 2030, other options start to become important: using biofuels instead of fossil fuels and solar/wind or nuclear power for power generation⁶. Indeed the largest reductions are likely to occur in the power sector as several fully competitive non-carbon emitting options exist for the level of carbon value implied by S550e and S650e.

Thermal generation with carbon capture and sequestration also plays an important role throughout the century in the S550e profile. Compared to other options, the largest contribution is in the first half of the century.

In the S650e profile, in contrast, only in the second half of the century is the carbon value sufficiently high to make plants with carbon capture and sequestration competitive against other electricity generation options. Also fuel-switching from coal to natural gas plays some role during the first half of the simulation period. In both the S550e and S650e profiles, renewables become a more attractive option during the second half of the century.

Figure 33: Emission reduction by mitigation measure for S550e (left) and S650e (right), PCC2050 case

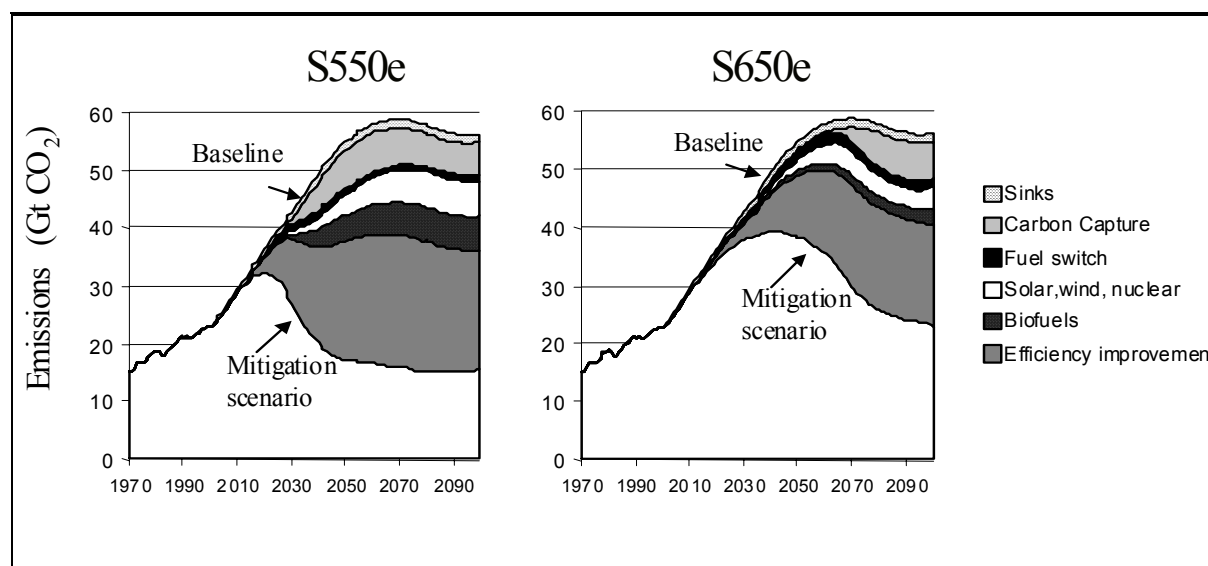

Source: TIMER 1.0

Climate policies can also have considerable impacts on energy production and trade flows. Figure 34 illustrates the changes in imports and exports of oil and other fuels. In 2025, the revenues from oil exporting countries, in particular the Middle East, are expected to be reduced by about 10% under S650e and by about 25% under the S550e profile. The impacts on oil trade are still larger in 2050, in both profiles. The loss of oil revenue is now, respectively, 20 and 35% for the Middle East. Interestingly however, losses for other oil exporting regions can be even higher. The CIS and Latin America, regions with higher

⁵ The actual size of each option depends somewhat on the order of attribution. We first determined the total contribution from efficiency improvement, next from penetration of solar/wind and nuclear power and biofuels, then from biofuel penetration and finally for a fuel-switch among the different fossil fuels.

⁶ We have allowed additional use of nuclear power as a mitigation option in these calculations. In fact, as the cost of this option is for most of the simulation period lower than the solar/wind power option, it represents a very attractive alternative in terms of a first response. The 'learning' capacity of this option is, however, assumed to be lower than for solar/wind power.

production costs than the Middle East but that are projected to become major oil exporting regions after 2025, are confronted with a significant loss of oil demand.

Interestingly, changes in the trade of other fuel can show a somewhat different picture. In the medium term (2010-2030), trade in natural gas represents is significant, and the impacts of climate policies is relatively small. By 2050, however, biofuel trade becomes a major issue. While both South America and CIS face losses in oil exports, these can be partly offset by biofuel production and export.

The financial flows involved by these changing fuel trade patterns are substantial compared to the direct costs of climate policies. This is shown in Table 29 in which the costs for the different regions in 2025 under the two Per Capita Convergence schemes are compared to the changes in costs and revenues of fuel trade. In 2025, the reduced oil imports could be important in Canada and USA, OECD Europe, South Asia and South-East and East Asia.

The loss of revenues seems to be particularly important for Africa (oil exports from Northern and Western Africa and coal exports from South Africa) and Middle East & Turkey. For these two regions, the loss of oil revenue could be much larger than the direct costs of climate policies. In 2050, a somewhat different picture emerges as modern biofuel trade might somewhat offset losses of oil trade.

Figure 34: Changes in fuel trade under S550e and S650e (PCC2050 case)

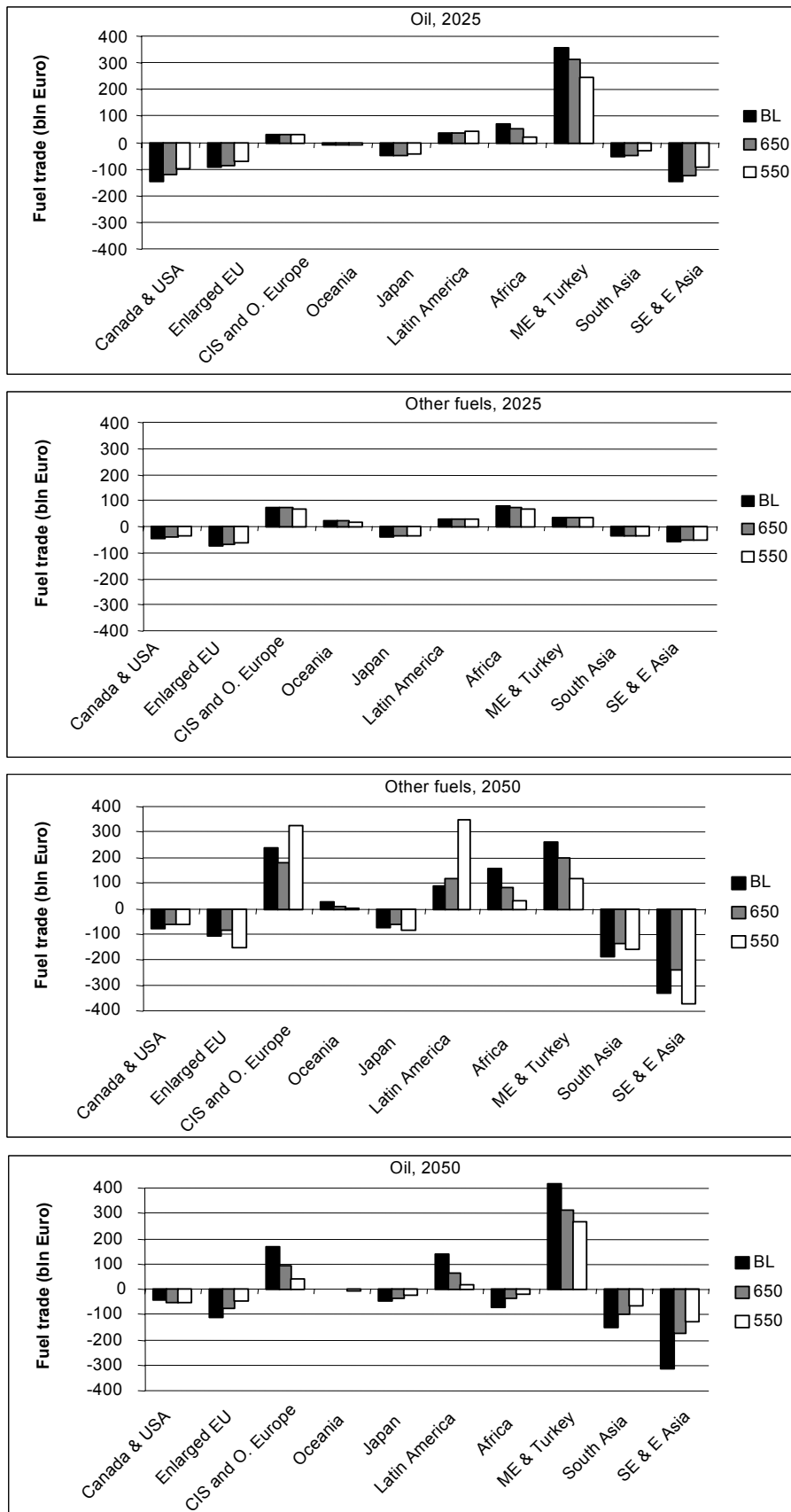

Source: FAIR 2.0/TIMER 1.0

Table 29: Costs of climate policies and impacts of fuel trade under the S550e profile, in 2025 and 2050

			Canada & USA	Enlarged EU	FSU	Oceania	Japan	Latin America	Africa	ME & Turkey	South Asia	SE & E Asia	World
			(bilhon Euro)										
2025	Climate policies	PCC2050	92	48	32	10	18	27	-27	49	-40	59	267
		PCC2100	39	31	9	7	13	29	8	46	11	71	265
	Fuel trade	Fossil	-52	-33	13	6	-13	-9	62	108	-23	-59	0
		Biofuels	-8	5	-4	0	2	2	0	0	1	2	0
2050	Climate policies	PCC2050	406	204	199	35	55	196	-144	264	-173	306	1350
		PCC2100	142	103	70	22	26	208	90	259	88	338	1346
	Fuel trade	Fossil	-27	-112	223	27	-54	102	52	276	-168	-319	0
		Biofuels	26	95	-185	4	42	-241	21	17	52	169	0

Source: TIMER 1.0

4.3.6. Conclusions

Emission trading and abatement costs for Multi-Stage & Per Capita Convergence cases

- The international carbon value for the S550e profile is much higher than for S650e. This can be explained by: i/ a much lower emission reduction burden for the S650e profile and ii/ the exponential form of the global MAC curve with fast increasing prices for the higher emissions reductions.
- In almost all cases explored, the Annex I regions plus Latin America and Middle East & Turkey are net buyers on the emissions trading market. In most cases, the sellers are the low-income non-Annex I regions, South Asia and Africa, but also South East & East Asia.
- For the S550e profile the global effort rate (abatement costs per unit of GDP) increases very fast between 2010 and 2040 to a maximum level of 1.2% of GDP, after which the effort rate gradually decreases. For the S650e profile, the effort rate increases gradually and stabilises after 2070 at only 0.3% of GDP.
- The effort rates differ largely across the different cases and regions. The differences can partly be explained by differences in required reductions, in abatement opportunities and regional GDP levels.
- In general, regions with high per capita emissions and per capita income are confronted with average effort rates (around 2% in 2050 for S550e and around 0.5% for S650e). Regions with medium to high per capita emissions, but medium to low per capita income (Middle East & Turkey and CIS) are confronted with the highest effort rates. In the long-term, Latin America falls also into this category. Other regions, with low per capita emissions are generally confronted with much lower costs, or even net gains resulting from emission trading.
- Except for the PCC2100 case, South Asia gains in all regimes, both in the short-term and in the long-term. The effort rate of Africa, on the contrary, differs greatly between the various regimes in the long-term: from 1.5% losses in the MS3 case to 2% gains in the PCC2050 case.

Implications for the energy system

- Changes in the energy system as a result of climate policies will be substantial, particularly in the case of the S550e profile, and the changes in the energy system will lead to higher costs for end users.
- The climate regimes do not have much influence on the nature of the impacts of global emission constraints on the energy system, as emissions trading results in the implementation of the most cost-effective options world-wide.
- Climate policies will also have significant impact on fuel trade. Oil exports from the Middle East, Latin America and CIS are projected to be significantly reduced. The latter two regions, however, might benefit from exports of modern biofuels. For the Middle East, losses of oil revenues are projected to be higher than greenhouse gas abatement costs.

5. Co-benefits of mitigation actions

The implementation of greenhouse gas abatement policies will have substantial impacts on the energy and economic systems through lower energy consumption, major inter-fuel substitutions and changes in economic activities. In particular, the emissions of local air pollutants in the different world regions will be significantly altered. Thus greenhouse gas reduction policies may also generate important positive side-effects on the ecosystems and on human health. These effects pertain to the broader category of 'co-benefits', that should be taken into account in any assessment of long-term climate policies.

The evaluation of environmental impacts and co-benefits – both in physical and economic terms – is a daunting task as many uncertainties still surround their quantification, in particular when an international perspective is adopted. Although the issue of environmental impacts and costs has been the focus of a lot of research in recent years (in the EC's ExternE programme for methodology and data gathering or in the RAINS programme for modelling) data are still scarce and incomplete for the different world regions.

This chapter is an attempt to draw a first assessment of the potential co-benefits of the greenhouse gas reduction pathways that have been identified and described in the chapters above. For this purpose two different approaches have been adopted:

- The first one focuses on the atmospheric emissions of SO₂ and NO_x, in a modelling framework that is based on the linking of the TIMER and of the RAINS models; changes in emissions are described in physical units, but the use of proxy indicators for air pollution effects allows to better characterize the positive consequences of greenhouse gas reduction policies; this approach is particularly relevant for those world regions that combine a rapid growth in their economic and energy systems and an already high vulnerable to air pollution problems, as is the case for Asia.
- The second approach is developed in a general equilibrium framework and uses the 'state of the environment' module of the GEM-E3 model; the transferability of data gathered in Europe or in the US to other world regions still raises important problems and the results should thus be considered as preliminary; however, this exercise allows to produce a first assessment of environmental co-benefits assessed in terms of welfare, which can be usefully compared with the costs of greenhouse gas abatement policies.

5.1. Co-benefits from the FAIR-TIMER-RAINS modeling

This chapter discusses the potential additional benefits – or co-benefits – of the mitigation scenarios presented above.

5.1.1. Co-benefits of climate policies for regional air pollution control

There is an increasing awareness in both the science and policy communities of the importance to address the linkages between the traditional air pollutants and greenhouse gases. Many air pollutants and greenhouse gases have common sources, their emissions interact in the atmosphere, and they cause separately or jointly a variety of environmental effects at the local, regional and global scales (see Text-box 3). Thus, emission control strategies that simultaneously address air pollutants and greenhouse gases may lead to a more efficient use of resources at all scales. Current studies indicate that in those high-income countries currently considering climate policies, potential co-benefits could be substantial and may reach up to 30-50% of total climate control costs.

Text-box 3: Linkages between climate change and regional air pollution

Several linkages exist between climate change and regional air pollution. First, some of the gases influencing climate change also impact regional air pollution, as for instance methane, sulphur, nitrogen oxide emissions. Second, the emissions causing both problems originate to a large degree from the same activity, i.e. fossil fuel combustion. Third, technologies for abatement of one pollutant may also affect emissions of other pollutants, either beneficially or adversely (e.g. the use of catalytic converters increases the emission of the greenhouse gas N₂O). Fourth, environmental effects may influence each other. Climate change, for instance, changes the weather patterns and thus the transport of pollutants and also the buffering capacity of soils ([Posch, 2002). It should be noted that linkages work in two directions: there can be synergies and trade-offs. In general terms, policies to reduce air pollutant emissions, such as switching from high-sulphur coal to low-sulphur natural gas, will also reduce carbon dioxide emissions (Mayerhofer et al., 2002). However, a well known example of a trade-off is the reduction of sulphur dioxide emissions and subsequently concentrations in the atmosphere, which will lead to less sulphur aerosols, thus limiting the cooling effect of sulphur aerosols (e.g., Charlson et al., 1992; Andreae, 1995).

On the other hand, climate change policy may have unforeseen consequences for air pollution abatement strategies. For example CO₂ trading will change the spatial distribution of air pollutant emissions and will have effects on regional air quality (Pearce, 2000; Van Vuuren et al., 2003). The environmental issues of which linkages are known to exist between Climate Change and Air Pollution are acidification, eutrophication, tropospheric ozone formation and urban air pollution, see for a more in depth description e.g. EEA (2003).

Table 30: Illustration of linkages between air pollution and climate change

	SO ₂	NO _x	NH ₃	VOC	CO	Primary PM+BC	CH	CO + GHGs
Ecosystems								
- Acidification	X	X	X					
- Eutrophication		X	X					
- Ground level ozone		X		X	X		X	
Health Impacts								
- direct	X			X	X	X		
- indirect by sec. aerosols & ozone	X	X	X	X	X		X	
Radiative forcing		X					X	X
- via aerosols	X	X	X	X		X		
- via OH		X		X	X		X	

In low-income countries, taking care of the potential synergies of climate change and air pollution policies could be even more important than in high-income countries. At the moment, in most cases both climate change policies and air quality control are still relatively marginal issues in these countries compared to issues such as poverty eradication, food supply, provision of energy services, employment and transportation. To curb the potential risks of fast growing emissions of both air pollutants and greenhouse gases in these countries, use could be made of the synergy between sustainable development, issues of national interest (energy, food) and climate change. Accelerated (sustainable) development could in this way be a mutual interest for both local and global communities.

In this study, some of the possible linkages between climate change and air pollutants at the global scale have been quantified by linking the TIMER model with the RAINS-Asia model.

At this stage not all linkages can be quantified at a global scale. We have focused our analysis on the consequences of climate policies on SO₂ and NO_x emissions and related environmental problems, looking in more detail at the Asia region. For this region we also estimated the changes in SO₂ related acidification risks. Figure 35 shows the methodology that has been used to calculate the critical load exceedances in Asia.

Figure 35: Overview of models used for the co-benefit study

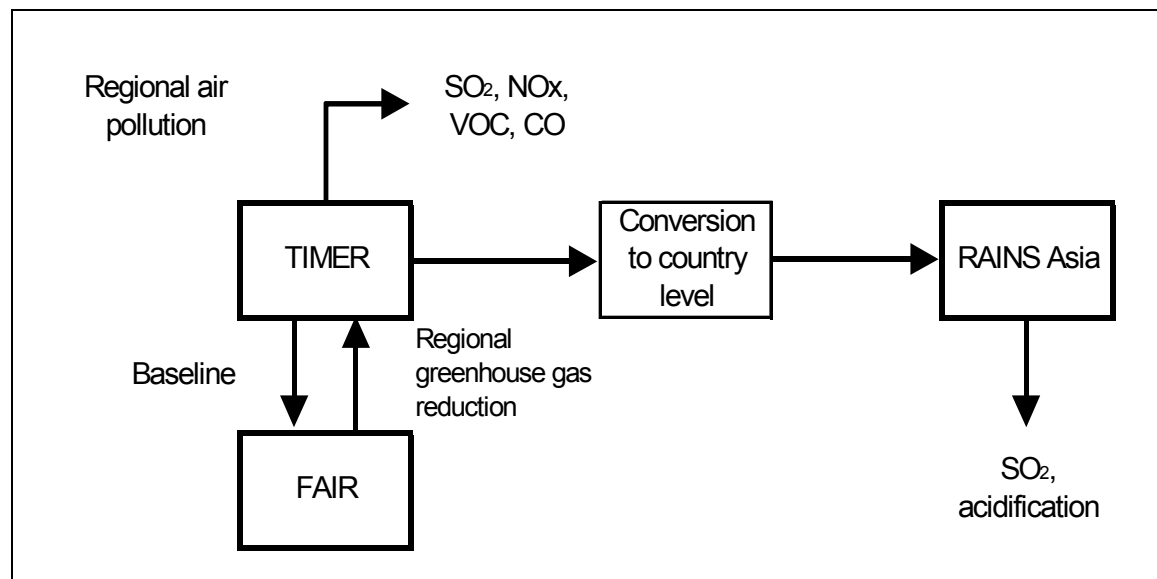

First, the FAIR model is used to determine the optimal multi-gas regional abatement of energy related greenhouse gas. In a next step, the TIMER energy model (and IMAGE 2.2 emission model) is used to calculate the changes in regional emissions of sulphur dioxide (SO₂), nitrogen oxides (NO_x), volatile organic compounds (VOC) and carbon monoxide (CO) resulting from greenhouse gas abatement measures in the energy system, while taking into account adopted regional air pollution targets. For calculating the change in acidification in the Asian regions, the regional energy production and consumption patterns of TIMER are converted to the country level of the RAINS-Asia model.

5.1.2. Potential co-benefits of the S550e and S650e mitigation scenarios

Changes in emissions of sulphur and nitrogen oxide

Figure 36 shows the changes in global sulphur and nitrogen oxide emissions under the baseline, S550e and S650e. The changes in the energy system result in considerable co-benefits. Sulphur and NO_x emissions are reduced significantly as a co-benefit of climate policies. The S650e leads to world-wide reductions of sulphur and nitrogen oxide emissions of 50% and 35% respectively compared to baseline. The S550e scenario leads to even stronger reductions, i.e. 70% and 50%.

Figure 36: Global sulphur (left) and nitrogen oxide (right) emissions under baseline and S550e and S650e profiles

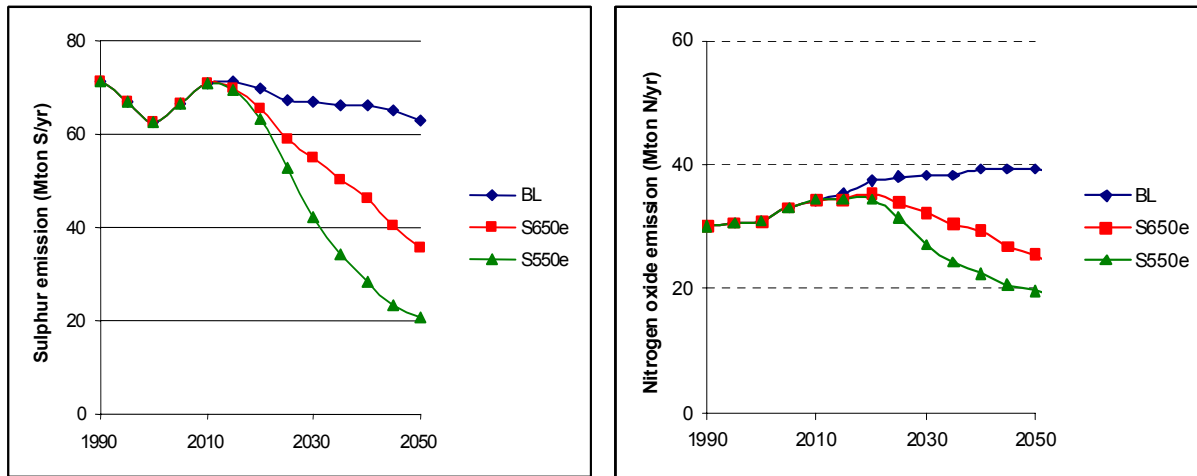

Source: IMAGE2.2/TIMER 1.0

These results can also be viewed in more detail at the regional level (Figure 37). It shows that co-benefits occur in all regions. However, as emissions of both sulphur and nitrogen oxide are largest in the low-income regions as a result of less strict air pollution control policies, in absolute terms co-benefits are largest in these regions. In particular the emissions in 2025 and 2050 in the Asian regions are relatively high.

Figure 37: Sulphur oxide emissions under baseline, S550e and S650e in 2025 (left) and 2050 (right)

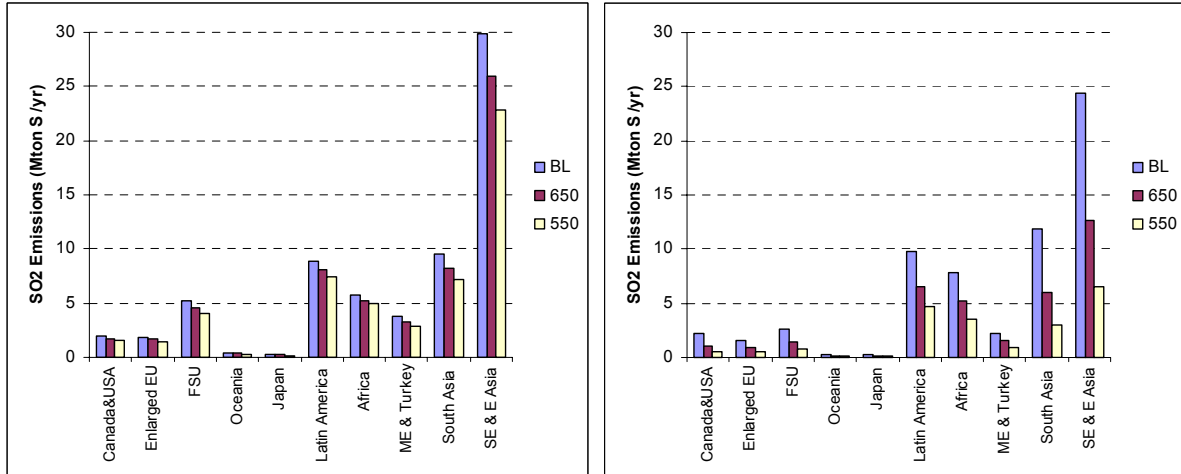

Source: IMAGE 2.2/TIMER 1.0

Figure 38: Nitrogen oxide emissions under baseline, S550e and 650e in 2025 (left) and 2050 (right)

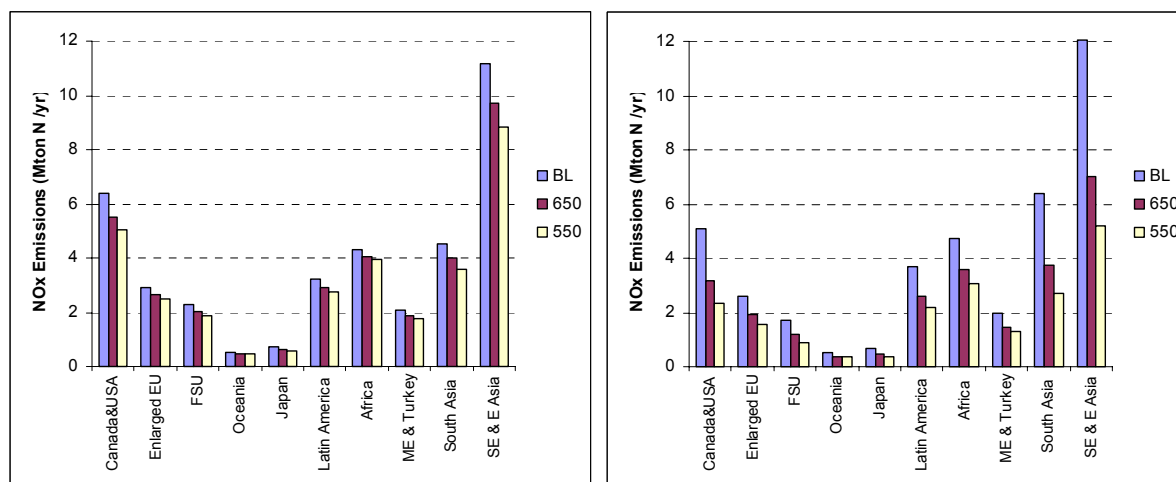

Source: IMAGE 2.2/TIMER 1.0

- *Potential impacts of emissions to ecosystems*

In order to estimate the potential consequences of these changes in emissions for acidification risks, we have calculated the ratio between regional emissions and the size of each region. This indicator gives a first indication on the potential acidification risks.

Figure 39 shows that under the baseline, many ecosystems are confronted with serious acidification risks, in particular in Asia. In 2025, the climate policy scenarios improve the risk indicator by 10% (S650e) to 20% (S550e). The differences between the baseline scenario and the climate policy scenarios become more obvious by 2050 as climate policies tighten. Now under the S550e scenario, the situation is expected to improve considerably (more than 70% reduction compared to baseline – significantly decreasing the likelihood of exceeding ecosystem critical loads).

Figure 39: Sulphur oxide emissions (kg.S/km2) under baseline, S550e and S650e in 2025 (left) and 2050 (right)

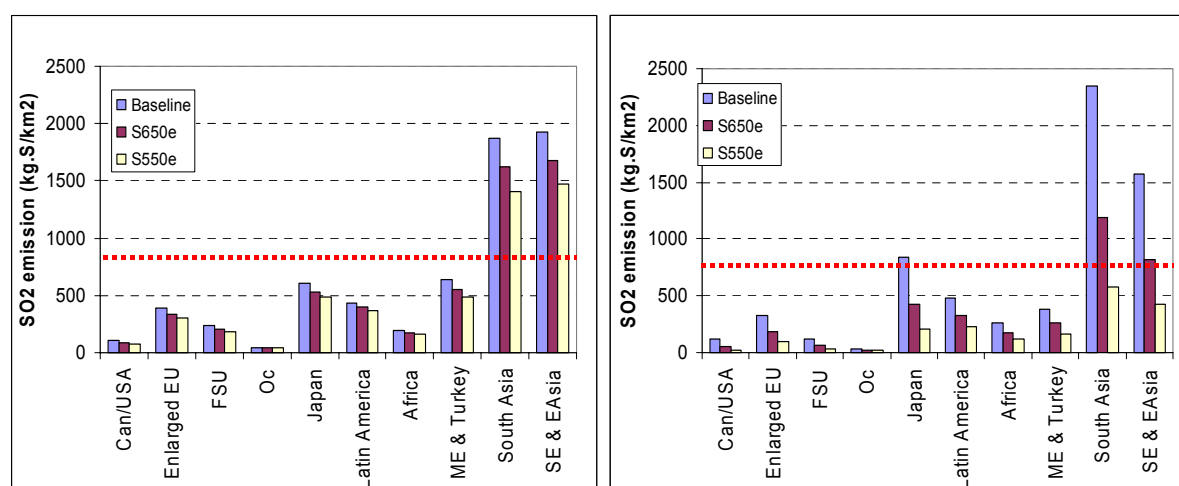

Note : The horizontal line indicates of a level above which risks of to ecosystem damage substantially increase (see also the text box in this session).

Source: IMAGE 2.2/TIMER 1.0

Also NO_x emissions are important for acidification and eutrophication risks. The highest emissions in 2025 and 2050 per square kilometre are expected in Japan (Figure 40). In 2025 NO_x emission are likely to exceed critical loads for all three scenarios also in (South)-Eastern Asia and Western Europe. By 2050 under the baseline assumption NO_x emissions are still high, somewhat improving in the S650e scenario and considerably under the S550e scenario (Figure 40).

Figure 40: Nitrogen oxide emissions (kg.N/km²) under baseline, S550e and S650e in 2025 (left) and 2050 (right)

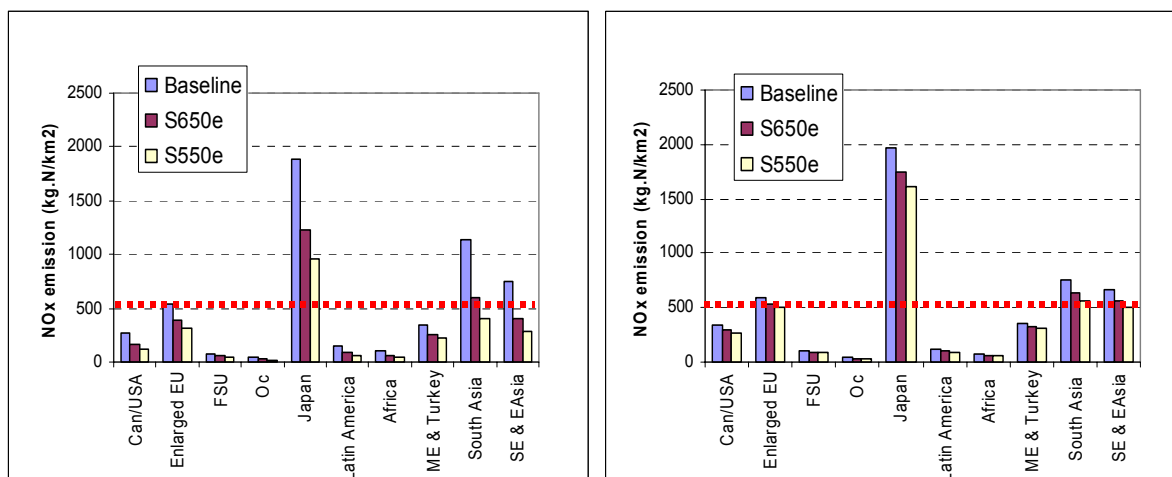

Note : The horizontal line indicates of a level above which risks of to ecosystem damage substantially increase (see also the text box in this session).

Source: IMAGE 2.2/TIMER 1.0

- *Potential benefits for human health impacts*

The largest benefits of climate policies for human health can be expected from the expected reduction of ozone and particles concentrations. As climate policies in general lower fossil fuel use, they also reduce related particulate emissions. Reduced exposure to these particulates can extend average life expectation by 2-3 years (Kovats et al, 1999, Mechler et al. 2002). Additional health benefits can be gained by reducing urban concentrations of NO₂ and SO₂.

In Figure 41 the urban emissions (assumed to be the sum of sectors transport, services and households) are given as kg/capita. In principle, this can serve as an indicator of health risks in cities assuming equal population density and vulnerability (e.g. meteorological conditions). It should be noted that in general the population density in Europe and Asia is higher than for instance the United States. Figure 41 shows that under the baseline in 2025 and 2050 under the baseline still serious health risks in cities exists, despite the fact that the situation slowly improves as result of more tightened air pollution standards in different parts of the world (with increasing income). The figure also shows the clear differences between the baseline scenario – and the climate change policies scenarios. It can be concluded that the likelihood to exceed NO₂ standards will be reduced by 2025 and continue to improve towards 2050.

Figure 41: Urban nitrogen oxide emissions under the baseline, S550e and S650e in 2025 (left) and 2050 (right)

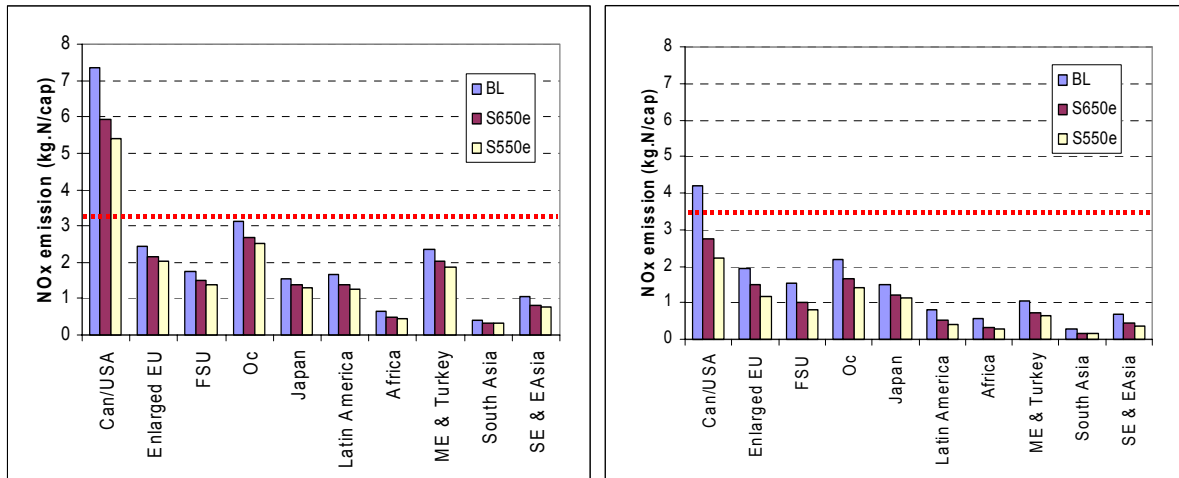

Note : The horizontal line indicates of a level above which risks of to ecosystem damage substantially increase (see also the text box in this session).

Source: IMAGE 2.2/TIMER 1.0

For SO₂ (Figure 42), urban air quality standards are still likely to be exceeded by 2025 for the Middle East and South East & East Asia regions. In 2050, under the baseline assumptions, exceedances are still likely in South East & East Asia.

Figure 42: Urban sulphur oxide emissions under baseline, S550e and S650e in 2025 (left) and 2050 (right)

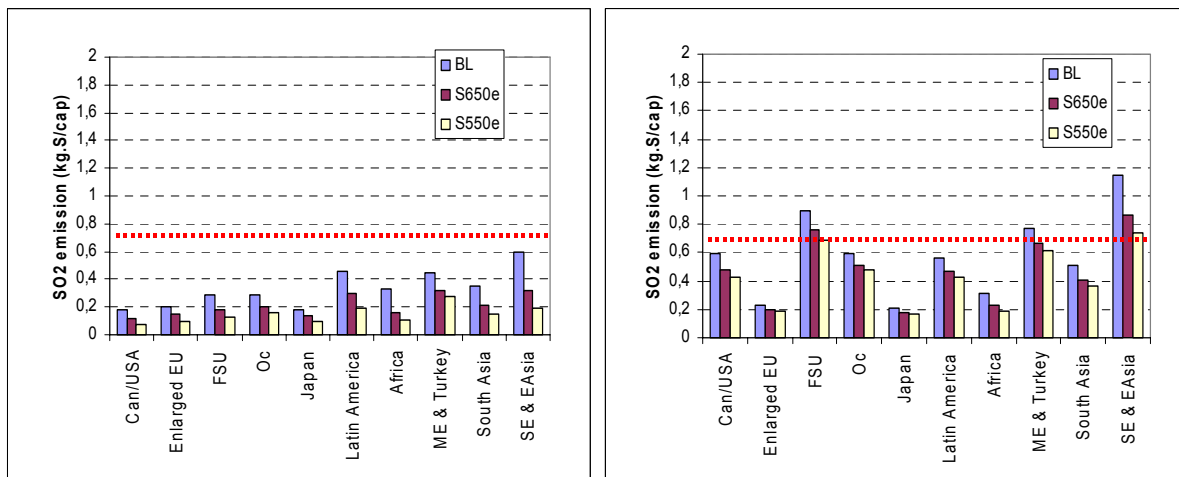

Note : The horizontal line indicates of a level above which risks of to ecosystem damage substantially increase (see also the text box in this session).

Source: IMAGE 2.2/TIMER 1.0

Text-box 4: Proxy indicators for air pollution effects

In this study, two indicators have been developed that can be used as a proxy for potential air pollution effects on ecosystems and human health. A short description of the assumptions underlying these indicators is given below.

Indicator for potential air pollution effects on ecosystems

Acidification and eutrophication have been recognised as major environmental problems since the early 1970s. The main responsible compounds are sulphur dioxide (SO₂, acidification only), nitrogen oxides (NO_x) and ammonia (NH₃).

Critical load is the maximum level of deposition of acidifying or eutrophying compounds on ecosystems that can be tolerated by the ecosystem without damaging effects. The critical load is dependent on the soil type, the ecosystem involved and the climate.

Based on a European critical load dataset, covering 5.7 million square kilometre of ecosystems, from the UN/ECE co-ordination centre for effects (e.g. Posch et. al, 2001) a regional average critical load value was derived. The derived threshold value chosen is based on an average protection of 90-95% of the ecosystems in a 150 x 150 km grid. For the S-indicator this resulted in a threshold of 250 mol S/hectare (500 mol/hectare in equivalent H, equivalent to 800 kg S/km²) and for the N-indicator (assuming equal contribution NO_x and ammonia) a threshold of 400 mol N/hectare (equivalent: 560 kg N/km²) for NO_x.

Indicator for potential effects of air pollutants on human health

NO_x, benzene, PAHs, SO₂, tropospheric ozone and particulate matter all contribute to “urban air pollution”. especially ozone and particulate matter (PM, but also called aerosols) have shown to have adverse effects on human health and are strongly related to the other air pollution problems (Lükewille et al., 2001). Recent epidemiological studies (PEACE, APHEA) have shown that quantitative assessment of urban air pollution effects on human health is possible. In this report, however, we have limited ourselves to describe exposure in relation to air quality guidelines.

The levels of urban air pollution are determined by:

- *The emission per square kilometre*
- *The size and shape of the city*
- *The location of the city (river basin versus valley)*
- *The meteorological conditions*
- *The height and heat content of the emission source*
- *The seasonal distribution of the emissions*

Based on the data available in the TIMER model the assessment of urban air pollution problems has been limited to the contribution of SO₂ and NO_x/NO₂. From the European data set an average threshold emission per square kilometre has been derived. Assuming an average urban population density of 10.000 inhabitants/km² this value has been converted to an emission per capita. To improve the indicator for a specific city the presented value can be scaled with the actual population density. The urban emission presented is assumed to be the sum of the sectoral emission contribution of households, transport and services. For SO₂ and NO_x (proxy for NO₂) the following values have been derived, based on an increased likelihood of exceedances occurring in at least 25% of the city surface:

- *0,7 kg S/capita (assuming a 75% contribution from regional sources)*
- *3,5 kg N/capita (assuming a 25% contribution from regional sources)*

5.1.3. Looking into more detail to changes in Asia

In the previous section we have seen that for ecosystems, the sulphur related acidification risks in 2025 and 2050 might be the worst in the Asian regions. Therefore, in this study the link between the TIMER and RAINS-Asia model has been developed to explore in detail the potential co-benefits in Asia. The energy scenarios developed in TIMER (CPI baseline, S650e and S550e) are transferred into the RAINS system and combined with the baseline assumptions for sulphur policy by country in RAINS⁷. The changes in the energy scenarios result in different sulphur scenarios within RAINS. Using the sulphur emissions, sulphur deposition and the resulting exceedances of critical loads of ecosystems for acidification have been calculated (Figure 43 and Figure 44).

Figure 43: Percentage of ecosystem areas with exceedance of critical loads

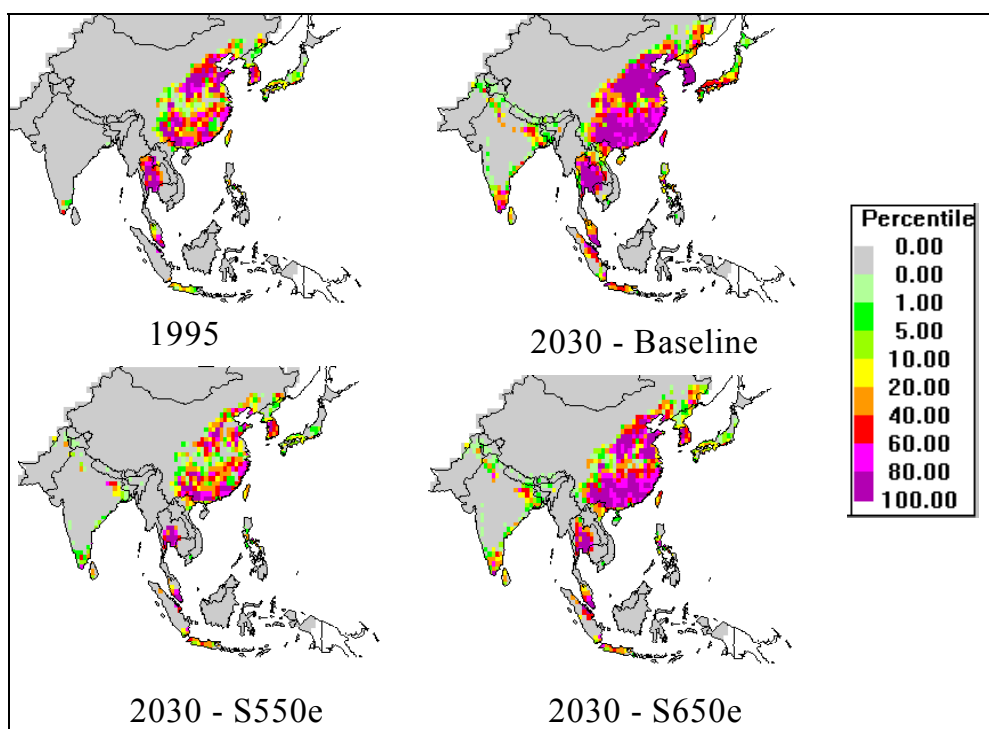

Note: The percentile value indicates the percentage of each grid cell surface where an exceedance of the critical level for acid deposition is exceeded.

Source: RAINS-Asia model

In 1995, 4% of the ecosystems in the RAINS Asia region experienced deposition of sulphur dioxide above the critical loads. This is especially high in East China with areas where up to 100% of the ecosystems are threatened. Under the baseline assumptions the number of ecosystems that receives an sulphur deposition above their critical loads increases substantially (see Figure 43). Beside China also Thailand, Malaysia, Indonesia and India have large surfaces with exceedances. In the S550e scenario the situation improves substantially and the number of exceedances reduces compared to 1995 and the baseline.

⁷ In general terms these assumptions are comparable to those in IMAGE, although somewhat less strict.

Figure 44: Percentage of ecosystem areas with exceedance of critical loads

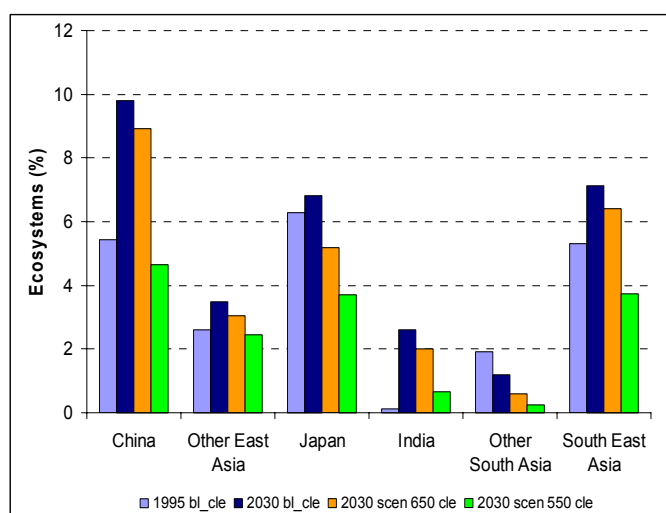

Source: RAINS-Asia model

Figure 45: Control costs to combat sulphur emissions

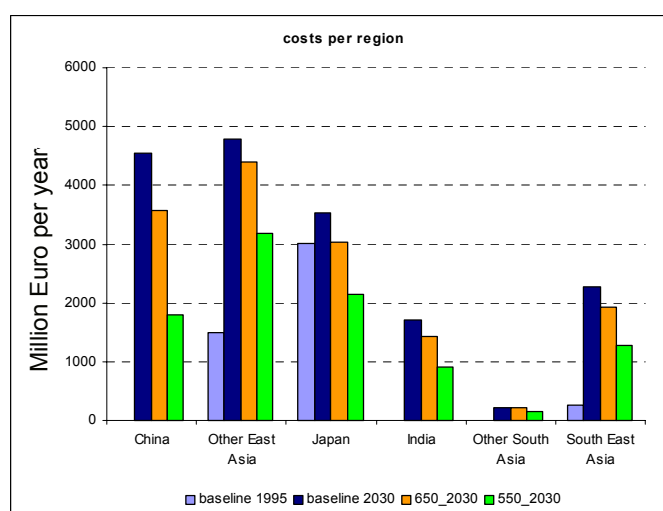

Source: RAINS-Asia model

Figure 45 shows the changes in air pollution control costs that are projected in these scenarios. As we assume the same level of air pollution control for different energy sources in each of our scenarios, reducing the use of these types of energy sources not only reduces emissions but also regional air pollution control costs. The figure shows that in most Asian sub-regions, the 2030 control costs of currently formulated policies are expected to be significantly higher than they were in 1995. In case of China, for instance, costs increase from a very low level to more than 4.5 billion Euro. The costs under the climate policy scenarios are substantially lower: while the S550e scenario has around 50% less acidification risks in China in 2030 than the baseline, the control costs are only a third of those of the baseline. Similar conclusions can be drawn for the other sub-regions, although in the other sub-regions the impacts tend to be smaller (around a 30% reduction of control costs). Due care is needed in comparing these gains in costs with the Climate Change costs presented earlier as different definitions of costs are used. However, it can be concluded with reasonable certainty that the savings of air pollution control costs form a substantial part of the total costs/benefits of this region under the various mitigation scenarios presented here.

5.1.4. Conclusions

A fully integrated assessment of the linkages between air pollution and climate change has not been performed yet. All studies undertaken so far show the importance of the links, which seem to be most relevant in the area of policy options and somewhat less so in the area of impacts. The economic studies of co-benefits of greenhouse gas mitigation suggest that the avoided damages can compensate sometimes a significant part of the costs of the measures, sometimes all. In the context of this study we have estimated some of the co-benefits on a world-scale that can be expected from the S650e and S550e mitigation scenario. The results show significant co-benefits with reductions of air pollution emissions and related problems in the order of 50% (similar to carbon dioxide reduction in case of sulphur). Both the S550e scenario and the S650e scenario increase the likelihood to respect urban air quality standards by 2025 and 2050 compared to the baseline.

For Asia, we have explored these co-benefits in more detail using RAINS Asia as calculations show that this region is among the regions most affected from air pollution in the world by 2030. The S550e scenario can limit the 2030 exceedance of critical loads in the total region by on average 50%, resulting in a slightly improved situation compared to 1995. The co-benefits of the S650e scenario are less. Here, most co-benefits can be expected after 2030.

5.2. Evaluation of co-benefits from GEM-E3 and ExterneE

The objective of this section is to give a first evaluation with the GEM-E3 World model of the co-benefits in terms of public health and ecosystem, which a global climate policy could imply for the participating countries. In the first part the modelling of the co-benefits in GEM-E3 is described and in the second part the results of the GEM-E3 simulations for two policy scenarios are presented.

5.2.1. Methodology for evaluating co-benefits in GEM-E3 World

- *Overall description*

Besides global warming, two important environmental problems are considered in GEM-E3: public health effects (acute morbidity and mortality, chronic morbidity, but no occupational health effects) due to energy-related emissions and problems related to deposition of acidifying emissions on agriculture, forests and materials (in a very aggregated way). The primary pollutants modelled are CO₂ and other greenhouse gas, NO_x, SO₂, VOC and particulates, which are the main sources of air pollution. The impact of ozone (O₃), a secondary pollutant formed by VOC and NO_x, is also evaluated. Damages to biodiversity, water and recreational fisheries and the consequences of nuclear accidents are not considered.

The 'state of the environment' module of GEM-E3 computes the emissions, their transportation over the different countries/regions and the monetary evaluation of the damages caused by emissions and depositions. The analysis is conducted on a marginal basis, i.e. it assesses the incremental effects and costs compared to a reference situation. It follows the 'impact pathway' approach as developed in ExterneE. The 'impact pathway' simply relates to the sequence of events linking a 'burden' to an 'impact' and its subsequent valuation.

Figure 46: An illustration of the main steps of the impact pathway methodology

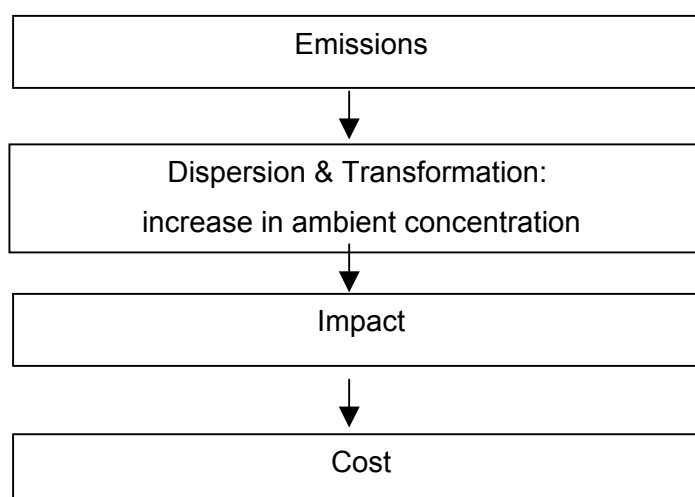

The calculation of emissions and dispersion/transformation is executed in the first and second step of the 'state of the environment' module. The calculated emissions of the primary pollutants are differentiated by countries/regions, sectors, fuels and durable goods that use the fuels. The changes in concentration levels of primary and secondary pollutants are determined through transport coefficients, relating the emissions in one country to the deposition/concentration in the country itself and in the other countries. For secondary pollutants (i.e. ozone), this implies to consider the relation between the emission of primary pollutants and the level of concentration of the secondary pollutants.

The impacts of incremental pollution and their valuation are determined in the last step of the 'state of the environment' module, based on the results from the ExternE study for the impacts of incremental pollutant emissions and the valuation of the related damages.

- **Basic assumptions for GEM-E3 World**

Because of the lack of specific data for each country/region, implementing such a module at World level requires general assumptions based on the data collected for GEM-E3 Europe. The extrapolation of EU or US data to the whole world raises different problems, which are extensively discussed in ExternE already for their European data: transferability of the results from specific studies, time and space limits, uncertainty, the choice of the discounting factor, the use of average estimates instead of marginal estimates and aggregation. However, despite all these uncertainties, it allows to get an informative quantified assessment of the environmental costs. The main data needed are emission coefficients per fuel, per sector and per region, parameters for the transformation and transboundary impact of pollutants and impact of pollution for the damage categories considered and their valuation.

Emission coefficients

The emission coefficients and their evolution over the time horizon of the simulations (2000-2030) were derived from the data in the GEM-E3 Europe model and the average emission coefficients obtained from the IMAGE model.

Transboundary and transformation parameters

There are no data at the level of aggregation of the GEM-E3 World model, therefore it has been assumed that the transport of pollutant occurs within each region and no transboundary effects are considered. For the impact of the deposition of pollutant on

concentration and for pollutant transformation, the figures for the EU in GEM-E3 Europe were used for all regions.

Damage and valuation

Data are also lacking here and the EU data are used with an adaptation for the extrapolation of the damage valuation. It is a crucial question, amply discussed in the theoretical and experimental literature on mortality valuation with still much research going on, especially as chronic mortality is one of the main source of damage from air pollution. Differences in terms of income, population age and health status, level of pollution are, among others, important parameters to take into account. As there does not seem to be a general consensus on the methodology to be used for such an extrapolation and the lack of specific data, the EU valuation data were extrapolated to the other model regions using only one criteria, per capita GDP. Because of the uncertainty attached to this extrapolation, two cases for the income elasticity were assumed, 0.4 and 1. The case where an equal damage valuation was used is certainly an extreme case and not very realistic in view of the results obtained to be discussed in the next section.

5.2.2. Co-benefits in the Multi-Stage 3 scenarios

Though there remains much uncertainty around the evaluation of the co-benefits because of lack of data and the aggregation level of GEM-E3 World, it seems still interesting to do this exercise to obtain an order of magnitude for these benefits. Two scenarios have been selected which differ in terms of the global target for greenhouse gas emissions, S550e-MS3 and S650e-MS3⁸, as this element drives the results in terms of local benefits. The climate policy simulated is a world wide greenhouse gas emission quotas system with an initial endowment defined by the rule adopted in the MS3 scenarios and global targets for emissions corresponding to the S550e and S650e profiles. No specific policy regarding local pollution is associated with this climate policy, though a policy optimising jointly the local and global pollution can reduce the country overall cost, when the greenhouse gas reduction target is not too high. The resulting emissions are given in Table 31 for both scenarios. The reduction of the local pollutant emissions are following rather closely the reduction in greenhouse gas emissions, as both are linked to the decrease in energy consumption.

⁸ For a same global reduction target, the emission reductions by regions are rather similar in the different scenarios, because the assumed world quota trading.

Table 31: Impacts on emissions of the MS3 scenarios in 2025

Emissions	S650e-MS3					S550e-MS3				
	GHG	Local Pollutants				GHG	Local Pollutants			
		NOx	SO2	VOC	PM		NOx	SO2	VOC	PM
USA	-19.7%	-14.0%	-21.0%	-10.6%	-19.3%	-40.2%	-34.3%	-44.9%	-28.4%	-41.7%
Canada	-15.1%	-11.3%	-18.9%	-9.5%	-16.6%	-32.6%	-29.7%	-42.0%	-26.7%	-37.8%
Australia & New Zealand	-14.7%	-10.8%	-13.2%	-11.2%	-11.7%	-33.3%	-30.1%	-35.4%	-31.1%	-32.0%
Japan	-6.6%	-3.6%	-4.8%	-3.7%	-4.5%	-17.9%	-13.3%	-17.4%	-13.8%	-16.1%
Enlarged EU	-9.5%	-4.9%	-7.7%	-4.1%	-6.9%	-22.8%	-16.6%	-23.5%	-14.7%	-21.6%
CIS	-19.0%	-10.4%	-6.7%	-4.7%	-14.7%	-39.8%	-29.9%	-20.4%	-19.1%	-36.9%
Middle East	-20.9%	-12.2%	-11.9%	-11.7%	-11.5%	-43.1%	-33.9%	-34.4%	-33.5%	-33.5%
Latin America	-10.9%	-5.8%	-4.6%	-4.6%	-6.6%	-21.4%	-18.0%	-15.6%	-15.1%	-19.3%
Africa	-11.8%	-6.6%	-6.4%	-5.0%	-7.4%	-24.8%	-20.1%	-20.8%	-16.4%	-21.4%
India	-25.0%	-29.6%	-36.3%	-21.8%	-38.2%	-41.3%	-50.8%	-58.9%	-41.1%	-60.6%
China	-25.3%	-25.2%	-27.8%	-20.7%	-28.9%	-47.5%	-49.9%	-53.8%	-43.4%	-55.2%
South and East Asia	-13.1%	-6.0%	-6.5%	-5.0%	-6.8%	-24.8%	-19.7%	-21.0%	-17.2%	-21.3%
World	-18.6%	-15.3%	-22.8%	-10.9%	-21.4%	-36.2%	-34.2%	-44.7%	-27.2%	-43.0%

Source : GEM-E3

The impact of the local benefits on welfare⁹, shown in Table 32, remains limited in most regions, though the reduction in the local pollutant emissions is substantial when the greenhouse gas emission reduction target increases. Expressed in terms of GDP, which shows the relative importance of these cost/benefits in total output, the changes are also small. In densely populated countries as India or China the impact can however become significant. The limited impact can be mainly explained by the rather low figures for the impact of changes in the pollution level derived in ExternE and used in the model. Moreover in the baseline scenario, there is already a substantial reduction in the emissions¹⁰ linked to energy reducing the potential for local benefits. Extrapolating the EU damage value to other regions proportionally to their relative GDP per head with an elasticity of 0.4 might underestimate the gain from the reduction in local damage, however using the same value for all regions is certainly overestimating the gain as it is difficult to justify that a country would not take measures to reduce a damage representing a cost of more than 10% of GDP as can be seen for China and India. The change in the overall welfare index for the world becomes positive, when the co-benefits are taken into account, reflecting the greater benefits in the most populated area.

⁹ The benefits from climate change are still marginal in 2025, so the difference between economic and total welfare is mainly due to the local benefits..

¹⁰ Reduction in the emission coefficient between 20% to 50% up to the horizon 2030 have been imposed.

Table 32: Economic assessment of the environmental impacts of the MS3 scenarios in 2025

2025	S650e-MS3						S550e-MS3					
	Gross Domestic product	Total Welfare (incl. envir. Benefits)	Economic Welfare	Local Benefits (% of GDP)*	Total Welfare	Local Benefits (% of GDP)*	Gross Domestic Product	Total Welfare (incl. envir. benefits)	Economic Welfare	Local Benefits (% of GDP)*	Total Welfare	Local Benefits (% of GDP)*
Macroeconomic Impact	Damage prop GDP/cap with elas 0.4			Damage as EU damage			Damage prop GDP/cap with elas 0.4			Damage as EU damage		
USA	-0.5%	-0.2%	-0.6%	0.2%	-0.3%	0.2%	-2.9%	-3.4%	-4.3%	0.5%	-3.4%	0.4%
Canada	-0.8%	-0.9%	-1.0%	0.0%	-0.9%	0.0%	-3.8%	-5.5%	-5.6%	0.0%	-5.5%	0.0%
Australia & New Zealand	-0.8%	-0.9%	-0.9%	0.0%	-0.9%	0.0%	-4.0%	-5.1%	-5.1%	0.0%	-5.1%	0.0%
Japan	-0.2%	-0.6%	-0.7%	0.0%	-0.6%	0.0%	-1.4%	-3.7%	-4.3%	0.1%	-3.8%	0.1%
Enlarged EU	-0.3%	-0.9%	-1.1%	0.0%	-0.9%	0.1%	-1.7%	-5.9%	-6.4%	0.2%	-5.8%	0.2%
CIS	0.2%	-5.3%	-6.1%	0.4%	-3.9%	1.1%	-2.6%	-33.2%	-34.9%	1.0%	-30.1%	2.9%
Middle East	-1.5%	-1.1%	-1.2%	0.1%	-0.9%	0.2%	-6.2%	-5.2%	-5.6%	0.2%	-4.8%	0.5%
Latin America	-0.3%	-0.2%	-0.2%	0.0%	-0.1%	0.1%	-1.4%	-0.5%	-0.6%	0.1%	-0.4%	0.2%
Africa	-0.3%	1.1%	1.0%	0.1%	1.4%	0.2%	-0.6%	7.3%	6.9%	0.2%	8.2%	0.7%
India	-0.2%	4.3%	1.8%	1.9%	18.5%	10.4%	-1.1%	10.3%	6.1%	3.2%	34.5%	17.1%
China	-1.1%	3.9%	1.1%	2.1%	15.8%	8.9%	-2.2%	16.2%	10.2%	4.1%	41.5%	17.2%
South and East Asia	-0.3%	-0.3%	-0.5%	0.1%	0.0%	0.3%	-3.1%	-5.9%	-6.5%	0.4%	-4.8%	1.0%
World	-0.4%	0.1%	-0.1%	0.3%	0.4%	1.2%	-2.2%	0.3%	-0.6%	0.7%	0.8%	2.3%

Source : Gem-E3

As in these simulations the co-benefits are evaluated ex-post, there is no feedback of these benefits on the consumption and production in the different countries/regions. Because of the uncertainty of figures used for the benefit evaluation such an analysis would not be credible. Exercises with GEM-E3 Europe comparing climate policy simulations with and without feedback have shown that taking into account the feedback can reduce the cost of the policies evaluated, though its impact is also limited.

Although these results are very preliminary due to the expected poor quality of external cost assessments at world level, they can provide some insights for the design of emission reduction policies that integrate the developing countries and take into account the external costs of energy in these countries. Though the impact on the cost of a climate policy remains limited, it is positive even at the aggregated level of GEM-E3 and without feedback and can be an incentive for the non-Annex I to join a greenhouse gas reduction agreement.

References

- Andreae, M.O., (1995). *Climatic effects of changing atmospheric aerosol levels*. In: *World Survey of Climatology*. Vol. 16: *Future Climates of the World*, A. Henderson-Sellers (ed). Elsevier, Amsterdam, pp. 341-392.
- Azar, C. and Dowlatabadi, H., 1999. *A review of technical change in assessment of climate policy*. *Annual Review of Energy and the Environment*, 24: 513-544.
- Banuri, T., Göran-Mäler, K., Grubb, M., Jacobson, H.K. and Yamin, F., 1996. *Equity and Social Considerations*. In: J.P. Bruce, H. Lee and E.F. Haites (Editors), *Climate Change 1995 - Economic and Social Dimensions of Climate Change, Contribution of Working Group III to the Second Assessment Report of the IPCC*. Cambridge University Press, Cambridge, UK.
- Bartsch, U. and Müller, B., 2000. *Fossil fuels in a changing climate: impacts of the Kyoto Protocol and developing country participation*. Oxford: Oxford University Press.
- Baumert, K.A., Bhandari, R. and Kete, N., 1999. *What might a developing country climate commitment look like?*, World Resources Institute, Washington DC.
- Baumert, K.A., Blanchard, O., Llosa, S. and Perkaus, J.F., 2002.- *Building on the Kyoto Protocol : Options for protecting the climate.- Washington D.C. : World Resources Institute*.
- Berk, M.M. and den Elzen, M.G.J., 2001. *Options for differentiation of future commitments in climate policy: how to realise timely participation to meet stringent climate goals?* *Climate Policy*, 1(4): 465-480.
- Berk, M.M., Van Minnen, J.G., Metz, B., Moomaw, W., Elzen, M.G.J.d., Vuuren, D.P.v. and Gupta, J., 2002. *Climate OptiONS for the Longterm (COOL) Global Dialogue Synthesis Report*, National Institute of Public Health and the Environment (RIVM), Bilthoven, The Netherlands.
- Blanchard, O., Criqui C., Kitous A., Viguier L., 2002. *'Efficiency with Equity : A Pragmatic Approach'*, in : Kaul I., Conceição P., Le Goulven K., Mendoza R.U., eds (2002). *Providing Public Goods : Managing Globalization*. Oxford University Press: Office of Development Studies, United Nations Development Program.
- Blanchard, O., Criqui, C., Trommetter, M. and Vinguier, L., 2001. *Equity and efficiency in climate change negotiations: a scenario for world emission entitlements by 2030*. *Cahier de Recherche No. 26, Institut d'Economie et de Politique de l'Energie (IEPE), Grenoble, France*.
- Charlson, R.J., S.E. Schwartz, J.M. Hales, R.D. Cess, J.A. Coakley, J.E. Hansen, D.J. Hofmann, (1992). *Climate forcing by anthropogenic aerosols*. *Science*, 255, 423-430.
- de Moor, A.P.G., M.M. Berk, den Elzen, M.G.J. and van Vuuren, D.P., 2002. *Evaluating the Bush Climate Change Initiative*. RIVM rapport 728001019/2002, National Institute of Public Health and the Environment, Bilthoven, the Netherlands.
- de Vries, H.J.M., D.P. van Vuuren, den Elzen, M.G.J. and Janssen, M.A., 2002. *The Targets Image Energy model regional (TIMER) - Technical documentation*. RIVM report 461502024, National Institute of Public Health and the Environment (RIVM), Bilthoven, the Netherlands.
- den Elzen, M.G.J. and Both, S., 2002. *Modelling emissions trading and abatement costs in FAIR 2.0 - Case study: the Bonn Agreement and Marrakesh Accords*. RIVM-report 728001021, Dutch National Institute of Public Health and the Environment, Bilthoven, the Netherlands.
- den Elzen, M.G.J. and de Moor, A.P.G., 2002b. *Evaluating the Bonn-Marrakesh Agreement*. *Climate Policy*, 2: 111-117.
- den Elzen, M.G.J. and Lucas, P., 2003. *a decision-support model to assess the environmental and economic consequences of future climate regimes*, www.rivm.nl/fair. RIVM-report 550015001, Dutch National Institute of Public Health and the Environment, Bilthoven.
- den Elzen, M.G.J. and Schaeffer, M., 2002. *Responsibility for past and future global warming: uncertainties in attributing anthropogenic climate change*. *Climatic change*, 54: 29-73.
- den Elzen, M.G.J., 2002. *Exploring climate regimes for differentiation of future commitments to stabilise greenhouse gas concentrations*. *Integrated Assessment*, 3(4): 343-359

- den Elzen, M.G.J., Berk, M.M., Lucas, P., Eickhout, B. and Vuuren, D.P.v., 2003a. *Exploring climate regimes for differentiation of commitments to achieve the EU climate target*. RIVM-report 728001023, Dutch National Institute of Public Health and the Environment (RIVM), Bilthoven.
- den Elzen, M.G.J., Berk, M.M., Lucas, P. and Criqui, C., 2003b. *Climate regimes for differentiating commitments for meeting the EU climate target and timely non-Annex I participation - the simplified Multi-Stage (MS) approach*. RIVM-report 728001024 (forthcoming), Dutch National Institute of Public Health and the Environment (RIVM), Bilthoven.
- den Elzen, M.G.J., Berk, M.M., Schaeffer, M., Olivier, O.J., Hendriks, C. and Metz, B., 1999. *The Brazilian proposal and other options for international burden sharing: an evaluation of methodological and policy aspects using the FAIR model*. RIVM-report 728001011, Bilthoven, the Netherlands.
- EEA, (2003a); Van Vuuren, D.P., J. Cofala, H.C. Eerens, R. Oostenrijk, M.G.J. den Elzen, C. Heyes, Z. Klimont, M. Amann, *Exploring the ancillary benefits of the Kyoto Protocol for air pollution in Europe*, EEA, Copenhagen, technical report (draft January 2003)
- EEA, (2003b), W. Tuinstra, R. Swart, J. van Minnen, D. Petroula, C. Brink, L. van Bree, H.C. Eerens*, E.-A. Kalognomou, N. Moussiopoulos, J. Cofala, Z. Klimont, M. Amann, F. Dentener, F. Raes *Air Quality and Climate Change Policies in Europe: Exploring linkages and the added value of an Integrated approach*, EEA, Copenhagen, first draft march 2003-03-03
- Eickhout, B., den Elzen, M.G.J. and van Vuuren, D.P., 2002. *Emission profiles to meet climate goals*. RIVM-report 728001024?, Dutch National Institute of Public Health and the Environment, Bilthoven.
- Enting, I.G., Wigley, T.M.L. and Heimann, M., 1994. *Future emissions and concentrations of carbon dioxide*. 0 643 05256 9, Mordialloc, Australia.
- Gupta, J., 1998. *Encouraging developing country participation in the climate change regime*, Institute for Environmental Studies, Vrije Universiteit, Amsterdam, the Netherlands.
- IMAGE-team, 2001. *The IMAGE 2.2 implementation of the SRES scenarios. A comprehensive analysis of emissions, climate change and impacts in the 21st century*. CD-ROM publication 481508018, Dutch National Institute for Public Health and the Environment, Bilthoven, the Netherlands.
- Jacoby, H.D., Schmalensee, R. and Wing, I.S., 1999. *Toward a Useful Architecture for Climate Change Negotiations*. Report No 49, MIT, Cambridge, MA.
- Kovats, R.S., B. Menne, A.J. McMichael, R. Bertollini, C. Soskolne (1999). *Early human effects of climate change and stratospheric ozone depletion in Europe*. WHO Background document to Third Ministerial Conference on Environment and Health, 16-19 June London.
- Lucas, P.L., den Elzen, M.G.J. and van Vuuren, D.P., 2003. *A Multi-gas abatement analysis of the Marrakesh Accords*. RIVM-report 550015002 (forthcoming), Dutch National Institute of Public Health and the Environment, Bilthoven, the Netherlands.
- Mayerhofer et al. (2002). *Long-term consistent scenarios of emissions, deposition, and climate change in Europe*. *Environmental Science & Policy*, 5, 273-305.
- Mechler, R., M. Amann, W. Schöpp, (2002). *A methodology to estimate changes in statistical life expectancy due to control of particulate matter air pollution*. IIASA interim report IR-02-035.
- Meyer, A., 2000. *Contraction & Convergence. The global solution to climate change*. Schumacher Briefings, 5. Green Books, Bristol, UK.
- Pearce, D., (2000). *Policy frameworks for the ancillary benefits of climate change policies*. In: *Ancillary Benefits and Costs of greenhouse Gas Mitigation*. Proceedings of an IPCC co-sponsored workshop, held on 27-29 March 2000, in Washington D.C. Organisation for Economic Co-operation and Development (OECD), Paris, pp. 517-560.
- Pershing, J., Philibert, C., 2002. *Beyond Kyoto, Energy Dynamics and Climate Stabilisation*. International Energy Agency. OECD/IEA, 2002.
- Philibert, C. and Pershing, J., 2001. *Considering the options: climate targets for all countries*. *Climate Policy*, 1(2): 211-227.

- Posch, M. (2002). *Impacts of climate change on critical loads and their exceedances in Europe. Environmental Science and Policy*. 5: 307-317.
- Ringius, L., Torvanger, A. and Holtmark, B., 1998. *Can multi-criteria rules fairly distribute climate burdens? - OECD results from three burden sharing rules. Energy Policy*, 26(10): 777-793.
- Ringius, L., Torvanger, A. and Underdal, A., 2002. *Burden sharing in international climate policy: principles of fairness in theory and practice. International Environmental Agreements: Politics, Law and Economics (in Press)*.
- Rose, A., 1992. *Equity Considerations of Tradable Carbon Emission Entitlements, Combating Global Warming. UNCTAD, Geneva*.
- Rose, A., Stevens, B., Edmonds, J. and Wise, M., 1998. *International Equity and differentiation in Global Warming policy, Mimeo, The Pennsylvania State University, California Energy Commission, and Pacific Northwest Laboratory, 31 July*.
- UNFCCC, 1997. *Paper no. 1: Brazil; Proposed Elements of a Protocol to the United Nations Framework Convention on Climate Change. UNFCCC/AGBM/1997/MISC.1/Add.3 GE.97, Bonn*.
- van Vuuren, D.P. and de Vries, H.J.M., 2001. *Mitigation scenarios in a world oriented at sustainable development: the role of technology, efficiency and timing. Climate Policy*, 1: 189-210.
- White-House, 2002a. *Executive Summary of Bush Climate Change Initiative*.
- White-House, 2002b. *Transcript of the speech of President Bush delivered at NOAA in Silver Spring, 14 February 2002*.

Appendix 1 – Regional breakdown

POLES and IMAGE / TIMER regions for the Greenhouse gas Reduction Pathways scenarios

North America	Canada United States	Australia	Australia American Samoa Cook Islands Fiji Kiribati New Caledonia Vanuatu Nauru New Zealand US Pacific Islands French Polynesia Solomon Islands Tonga Western Samoa Wake Island	Africa	Egypt Algeria Libyan Arab Jamahiriya Tunisia Morocco Western Sahara Benin Burkina Faso Cameroon Cape Verde Central African Republic Chad Congo Congo, the Democratic Republic of the Côte d'Ivoire Equatorial Guinea Gabon Ghana Guinea Gambia Guinea-Bissau Liberia Mali Mauritania Niger Nigeria Saint Helena Sao Tome and Principe Sierra Leone Senegal Togo Angola Botswana Lesotho Mozambique Malawi Swaziland Tanzania, United Republic of Zimbabwe Zambia Burundi Comoros Djibouti Eritrea Ethiopia Kenya Madagascar Mauritius Réunion Rwanda Seychelles Sudan Somalia Uganda	Middle East & Turkey	Israel Jordan Lebanon Syrian Arab Republic United Arab Emirates Bahrain Iran, Islamic Republic of Iraq Kuwait Oman Qatar Saudi Arabia Yemen Turkey
Enlarged EU*	France United Kingdom Italy Germany Austria Belgium Luxembourg Denmark Finland Ireland Netherlands Sweden Spain Greece Portugal Gibraltar Iceland Norway Switzerland Hungary Poland Czech Republic Slovakia Estonia Latvia Lithuania Slovenia Malta Cyprus Bulgaria Romania Albania Bosnia and Herzegovina Croatia Macedonia, the former Yugoslav Republic of Yugoslavia	Japan	Japan				
		Latin America	Mexico Bahamas Belize Bermuda Barbados Costa Rica Cuba Cayman Islands Dominica Dominican Republic Guadeloupe Grenada Guatemala Honduras Haiti Netherlands Antilles Jamaica Saint Kitts and Nevis Saint Lucia Leeward Martinique Nicaragua Panama El Salvador Turks and Caicos Islands Trinidad and Tobago Saint Vincent and the Grenadines Brazil Argentina Bolivia Chile Colombia Ecuador Falklands Islands (Malvinas) French Guiana Suriname Guyana Peru Paraguay Uruguay Venezuela				
FSU & R. Europe	Ukraine Kazakstan Kyrgyzstan Tajikistan Turkmenistan Uzbekistan Belarus Moldova, Republic of Russian Federation Armenia Azerbaijan Georgia						
						South Asia	India Pakistan Afghanistan Bangladesh Bhutan Sri Lanka Maldives Nepal
						SE & E Asia	Korea, Republic of Korea, Democratic* ople's Republic of China Hong Kong Macau Mongolia Taiwan, Province of China Brunei Darussalam Myanmar Cambodia Lao People's Democratic Republic Malaysia Philippines Singapore Thailand Viet Nam Indonesia Papua New Guinea